

Guidance from AIM Global's RFID Expert Group:

Proposed Guidelines for the Use of RFID-Enabled
Labels in Military Logistics:
Recommendations for Revision of MIL-STD-129



**Association for Automatic
Identification and Mobility**

*Document type: AIM Global RFID Guideline
Document Version : 1.06, 2005-05-13*

This guideline was developed by the RFID Experts Group of AIM, Inc., the trade association for manufacturers and providers of automatic identification and mobility products, services and supplies.

The guideline is intended as an aid the manufacturer, the consumer, and the general public.

NOTE: THIS DOCUMENT MAY BE REVISED OR WITHDRAWN AT ANY TIME.

Published by:

AIM, Inc.
125 Warrendale-Bayne Road
Suite 100
Warrendale PA 15086
Phone: +1 724 934 4470
Fax: +1 724 934 4495
Internet email: aidc@aimglobal.org
Web: <http://www.aimglobal.org>
Copyright © AIM, Inc. 2004

All rights reserved. No part of this publication may be reproduced in any form, in an electronic retrieval system or otherwise, without the prior written permission of the publisher.

05/05 V1.06

It is the intent and understanding of AIM, Inc., that the information presented in this specification is entirely in the public domain and free of all use restrictions, licenses and fees.

Neither AIM, Inc. or its individual officers, affiliates, or member companies, nor the members of RFID Experts Group individually or collectively assume any liability for the use of this document.

ABOUT AIM GLOBAL

AIM Global, the trade association for the Automatic Identification and Mobility industry, is the source for technically accurate, unbiased, commercial-free, and up-to-date information on all AIM technologies including:

Bar Code including 2-D Symbologies
Biometrics
Enterprise Mobile Computing
Machine Vision
Magnetic Stripe
Optical Cards
Optical Character Recognition

Radio Frequency Identification
Smart Cards
Touch Memory
Voice Recognition
WLAN

The association serves members world-wide through a network of AIM chapters.

Our member companies represent a wide array of AIDC technologies either as manufacturers or as providers of equipment, systems, and services. A listing of AIM Global's membership and chapters can be found at (<http://www.aimglobal.org>)

The Association and the REG would like to thank our Project Editors:

Clive P Hohberger, PhD
R J (Bud) Klein

Zebra Technologies Corporation
Paxar Corporation

Revision History

V1.06	Sections 7.3.2.2 and 8.2.2.2	Corrected DoD Header value to $2F_{\text{hex}}$
v1.05	Revision History Section 7.3.1	Added this Section to document Modified specification of the printed human readable version of the 96-bit binary data structure stored in the transponder
v1.04	Section 2.16 Section 4.8.1 Section 7.3.2.2 Section 8.2.2.2	Added DoD reference on UID guideline Enlarged and added legend to Figure 2 Added reference to UID guideline Added reference to UID guideline
v1.03	Title Page Annex A Annex C.4.1	Added Subtitle, "Recommendations for Revision of MIL-STD-129" Clarified description of "Leading Edge" of label roll or pack Modified measurement technique for transponder threshold power
v1.02		First published version

Table of Contents

Revision History	2
Table of Contents	3
1 Introduction and scope of this document	6
2 Relevant standards	6
2.1 US Department of Defense standards and guidelines.....	6
2.1.1 MIL-STD-129P Military Marking for Shipment and Storage.....	6
2.1.2 MIL-STD-1168 Ammunition Lot Numbering and Ammunition Data Card.....	6
2.1.3 MIL-STD-2073-1 Standard Practice for Military Packaging.....	6
2.1.4 MIL-PRF-61002 Pressure-sensitive Adhesive Labels for Bar Coding.....	7
2.1.5 MIL-STD-464A Electromagnetic Environmental Effects: Requirements for Systems.....	7
2.1.6 Department of Defense Guide to Uniquely Identifying Items, v1.4.....	7
2.2 NATO standards.....	7
2.2.1 STANAG 4281 NATO Standard Marking for Shipping and Storage.....	7
2.2.2 STANAG 2233 Standardization Agreement: NATO Consignment and Asset Tracking by Radio-Frequency Identification.....	7
2.3 EAN.UCC.....	7
2.3.1 General EAN.UCC Specifications, Version 5.0.....	7
2.4 EPC Global.....	7
2.4.1 EPCglobal Class 0 specification.....	7
2.4.2 EPCglobal Class 1 specification.....	7
2.4.3 EPCglobal Generation 2 specification.....	7
2.4.4 EPC Tag Data Standards Version 1.1 Rev 1.24.....	7
2.5 ISO/IEC standards.....	7
2.5.1 ISO 15394:2000(E).....	7
2.5.2 ISO/IEC 18000.....	7
2.5.3 ISO/IEC 18046 RFID device performance test methods.....	7
2.5.4 ISO/IEC 18047-6.....	7
3 Passive RFID Transponder Selection	8
3.1 Transponder selection.....	8
3.2 Passive UHF transponder frequency considerations.....	8
3.3 UHF transponder design factors.....	8
3.4 Transponder life and failure modes.....	8
3.4.1 Flexure and minimum bending radius of the RFID-enabled media.....	8
3.4.2 Environmental considerations.....	9
4 Passive RFID-enabled media construction	9
4.1 Basic RFID-enabled media configurations.....	9
4.1.1 Pressure-sensitive labels.....	9
4.1.2 Dry-gum (water-activated) adhesive labels.....	9
4.1.3 RFID-enabled tickets used in carrier envelopes.....	9
4.1.4 Tie-on tags.....	10
4.2 Environmental considerations in media design.....	10
4.2.1 Operating and storage temperature ranges of applied RFID-enabled labels.....	10
4.2.2 Storage of RFID-enabled labels.....	10
4.3 Label, ticket and tag printable facestocks.....	10
4.4 Printing method and ink compatibility.....	10
4.5 Permanent label adhesives.....	11
4.5.1 Adhesive RF properties and transponder compatibility.....	11
4.5.2 Hygroscopic adhesives.....	11

4.6	Removable label adhesives	11
4.7	Release liners (backing) for pressure-sensitive labels	11
4.7.1	Adhesive compatibility and release level	11
4.7.2	Removing the RFID-enabled label from the release liner	12
4.7.3	RF properties of release liners	12
4.8	Avoiding electrostatic discharge (ESD)	12
4.8.1	Transponder antenna design considerations	13
4.8.2	Printer-encoder considerations	13
4.8.2.1	ESD in thermal transfer printers	13
4.8.2.2	ESD in Laser and LED printers	13
4.8.3	Peeling as a source of static electricity	13
4.8.4	Conveyors as sources of static electricity	13
4.8.5	ESD compliance testing	14
5	Printing and encoding RFID-enabled labels	14
5.1	Printing methods.....	14
5.2	Label edge start sensing issues	14
5.3	Encoding and/or verifying transponder data.....	14
5.4	Dealing with defective transponders	14
6	RFID-enabled label placement.....	15
6.1	RF influence of the package and its contents on the transponder.....	15
6.2	Visual inspection method for determining label placement.....	16
6.3	Transponders for objects primarily acting as RF reflectors.....	17
6.3.1	Dielectric spacer materials and design considerations	17
6.4	Transponders for objects primarily acting as RF absorbers.....	17
6.4.1	Isolation using reflective underlabels	18
6.5	Some common packaging problems	18
7	RFID labeling of conveyable cases and containers	18
7.1	Definition of a conveyable object.....	18
7.1.1	Transport packages (cases and cases).....	19
7.1.1.1	Recommended RFID-enabled label placement	19
7.1.1.2	Read range performance requirement	20
7.1.2	Reusable plastic totes, delivery trays, etc.	20
7.1.3	Other conveyable goods	20
7.2	RFID reader assumptions	20
7.3	Label format and transponder data structure	20
7.3.1	Printed label format	20
7.3.2	Transponder data structure	21
7.3.2.1	EPCglobal data structures	21
7.3.2.2	DoD data structures	21
7.3.3	Use and reuse of the SSCC-96 transponder	22
7.4	Use of multiple RFID-enabled labels.....	22
8	RFID labeling of palletized unit loads	22
8.1	RFID reader assumptions	23
8.1.1	Portal readers	23
8.1.2	Forklift-mounted readers	23
8.1.3	Pallet conveyor readers	23
8.1.4	Handheld readers.....	23
8.2	RFID-enabled label usage and placement on pallet unit loads.....	23
8.2.1	General rules for unit load RFID-enabled label location	23
8.2.2	Transponder data structure	25
8.2.2.1	EPCglobal data structures	25
8.2.2.2	DoD data structures	25
8.2.3	Wooden and plastic pallets	26
8.2.4	Special considerations for bin, cage, and tub pallet containers	26

8.3	Permanent RFID labeling of pallets.....	26
9	Non-conveyable and non-palletized materiel.....	27
9.1	RFID reader assumptions	27
9.2	Guidelines for some common types of objects and packages.....	27
9.3	Label printed format and transponder data structure	27
9.4	Use of multiple RFID-enabled labels.....	27
	Annex A Design terms for RFID-enabled Labels	28
	Annex B AIM RFID Mark for RFID-enabled labels.....	30
	Annex C Optimizing RFID-enabled label placement.....	32
C.1	Equipment	32
C.2	Facilities Set up	33
C.3	Equipment setup.....	34
	C.3.1 RF cabling considerations.....	34
	C.3.2 Reader setup.....	34
C.4	Test methodology.....	34
	C.4.1 Taking threshold power measurements.....	34
C.5	Transponder and RFID-enabled label evaluation	35
	C.5.1. Measurement setup.....	35
	C.5.2 Evaluating transponder lot quality	35
	C.5.3 Evaluation effects of transponder orientation.....	35
	C.5.4 Influence of packaging materials.....	35
	C.5.5 Frequency influence	36
	C.5.6 Combination testing.....	36
C.6	Testing transport packages	36
	C.6.1. Measurement setup.....	36
	C.6.2 Taking measurements.....	36
	C.6.3 Constructing a transponder placement map	36
	C.6.4 Evaluation effects of transponder polarization	37
	C.6.5 Frequency influence	37
	C.6.6 Combination testing.....	38
C.7	Three-dimensional transport package testing	38

1 Introduction and scope of this document

The objective of this document is to provide background, reference information, and practical knowledge in the selection and application of “RFID-enabled” media—that is conventional labels, tickets and tags *with embedded or attached RFID transponders*—to the labeling of military goods and assets. This document does not address “smart packaging” where the transponder is embedded in the container itself.

Much of the work contained within this document is being proposed as additions to MIL-STD 129 and MIL-STD 130 but is not official U.S. Department of Defense (DoD) policy. Labelers are directed to MIL-STD 129 and MIL-STD 130 as the authoritative references.

The performance of RFID devices, particularly those operating at UHF frequencies (860-960 MHz) are strongly influenced by the construction of the RFID-enabled label, where it is applied to the object, and the RF characteristics of the underlying object or objects. In this regard, much more care has to be taken in selection and placement of the RFID-enabled label on the object than with a conventional bar code label as specified in MIL-STD-129. This in turn requires the additional knowledge and practical guidelines for RFID-enabled label selection and usage provided here.

Military applications have a wider variety of objects and materials that have to be labeled than are typical of commercial logistics. However, many ordinary food and consumer products are used in common. This is particularly true of goods transported in conveyable cases and pallets, totes and drums. *These guidelines have been coordinated with commercial logistics RFID practice so that conveyable goods used in common in military and civilian applications may conform to a common standard as far as possible.*

2 Relevant standards

2.1 US Department of Defense standards and guidelines

2.1.1 MIL-STD-129P Military Marking for Shipment and Storage

The nominal 4”x6” portrait-format Military Shipping Label (MSL) as specified in MIL-STD-129 Section 4.2.2 shall be placed as described in Section 4.3.2 of that document. Placement for many types of containers is described. If an RFID transponder is embedded in the Military Shipping Label, then this specifies its general area of placement.

Identification bar code marking labels for use on the exterior of non-ammunition shipping container are defined in Section 4.4 of MIL-STD-129P. Label placement is specified under Section 4.4.3 of that same document.

Section 5.1.2 of MIL-STD-129P document defines the basic material and performance requirements for water-resistant pressure sensitive labels for use under MIL-STD-129. Additional requirements for the nominal 4”x4” pressure-sensitive labels for ammunition and explosives containers are given in 5.6.5.1 of that document.

Identification bar code marking labels for use on the exterior of ammunition and explosives exterior shipping containers are defined in Section 5.6.2 of MIL-STD-129P, along with their placement is specification.

2.1.2 MIL-STD-1168 Ammunition Lot Numbering and Ammunition Data Card

2.1.3 MIL-STD-2073-1 Standard Practice for Military Packaging

2.1.4 MIL-PRF-61002 Pressure-sensitive Adhesive Labels for Bar Coding

2.1.5 MIL-STD-464A Electromagnetic Environmental Effects: Requirements for Systems

2.1.6 Department of Defense Guide to Uniquely Identifying Items, v1.4

2.2 NATO standards

2.2.1 STANAG 4281 NATO Standard Marking for Shipping and Storage

2.2.2 STANAG 2233 Standardization Agreement: NATO Consignment and Asset Tracking by Radio-Frequency Identification

2.3 EAN.UCC

2.3.1 General EAN.UCC Specifications, Version 5.0

2.4 EPC Global

2.4.1 EPCglobal Class 0 specification

2.4.2 EPCglobal Class 1 specification

2.4.3 EPCglobal Generation 2 specification

2.4.4 EPC Tag Data Standards Version 1.1 Rev 1.24

2.5 ISO/IEC standards

2.5.1 ISO 15394:2000(E)

2.5.2 ISO/IEC 18000

2.5.3 ISO/IEC 18046 RFID device performance test methods

This ISO Technical Report defines test methods for performance characteristics of RFID devices (tags and interrogation equipment) for item management, and specifies the general requirements and test requirements for tag and interrogator performance that are applicable to the selection of the devices for an application. It does not apply to testing in relation to regulatory or similar requirements.

2.5.4 ISO/IEC 18047-6

3 Passive RFID Transponder Selection

The term *passive RFID transponder* is used to describe the combination of an RFID integrated circuit (chip) bonded to an antenna, where the antenna is used for both two-way wireless communication and to draw power from the reader RF signal to operate the RFID chip.

3.1 Transponder selection

The preferred passive RFID transponder chip for Department of Defense applications meets the pending EPCglobal Class 1 Generation 2 specifications referenced in Section [2.4.3](#) and contains 96-bit data structures with an added internal 16-bit CRC. Additional transponder types may be utilized in the future, once defined.

In the interim, it is recommended that only 96-bit EPCglobal Generation 1 Class 0 and Class 1 transponders with approved 96-bit EPCglobal and US DoD data structures be utilized in early deployments. Note that the use of 64-bit transponders with the approved 64-bit EPCglobal and DoD data structures is NOT recommended. This is because of their limited encoding capability, decoding complexity, and the fact they will be rapidly superseded by 96-bit transponders when EPCglobal Class 1 Generation 2 transponders when commercially available.

Note on Class 0 and 0+: The EPCglobal Class 0 reader protocol identically reads both the Class 0 96-bit factory programmed transponder and the lower memory page of the 256-bit Class 0+ read-write transponders. Class 0+ transponders may be utilized as an interim solution provided only a single 96-bit EPCglobal or US DoD data structure is programmed into the lower 128-bit memory page Class 0+ transponder memory, and the upper memory page is not used.

3.2 Passive UHF transponder frequency considerations

RFID readers are subject to local regulations regarding frequency and allowed reader power. For example, in North America, the nominal operating frequencies are 902-928 MHz, conforming to FCC Part 15.247. In Europe, the nominal operating frequencies are 865-868 MHz, conforming to EN 302-208-1. In Japan, the pending nominal frequencies are in the range of 948-956 MHz, conforming to the Radio Law of Japan. Local regulations should be consulted before purchasing and deploying UHF RFID readers.

The transponder, when applied to the package, preferably shall be *functional* over the full range of UHF RFID frequencies that are approved for use in most countries, i.e. 860 MHz to 960 MHz. It is acknowledged that transponder reading performance may differ in different regulatory environments.

3.3 UHF transponder design factors

UHF transponder antennas may be fabricated in a number of ways. Antennas produced by each process have different electrical and mechanical properties. It is important to determine that the chosen RFID-enabled media performs according to the RFID transponder performance specifications when it is mounted on the transport case or unit load pallet of interest. The key parameter here is the range at which the label and case (or pallet) combination can be properly read at the required distance and orientation. Standard test methods are described in ISO/IEC 18046 (see Section [2.5.3](#)). Simplified lab methods are given in [Annex C](#).

3.4 Transponder life and failure modes

The method of transponder construction affects its technical performance, operating life, and environmental compatibility, as well as its cost. Certain special considerations apply.

3.4.1 Flexure and minimum bending radius of the RFID-enabled media

Depending on the materials and methods used in production of the transponder antenna and the chip bonding method, every transponder has a minimum allowed bending radius (radius of curvature). Flexing

or bending the finished RFID-enabled media to a radius smaller than this minimum radius at any point in the application process may result in RFID failure either from antenna fracture or breaking of the chip-antenna bond.

The RFID label manufacturer should be able to provide the value for the minimum-bending radius. In absence of specific information, one practical rule is to never bend the RFID-enabled labels to a tighter radius than that of the core on which the labels were supplied.

3.4.2 Environmental considerations

Environmental conditions for storage, transportation, and in-use operations should be specified by DoD to the manufacturer of the RFID-enabled labels based on the intended usage, e.g. the required working temperature and humidity, and any other unusual environment conditions expected of the object being labeled. The RFID-enabled media must only survive the same environmental conditions as the materiel and container onto which the RFID-enabled media is attached, over its intended working life.

Both extreme limits and cycling of environmental conditions can reduce RFID-enabled media operating life. Failure modes include chip-bonding failure and antenna fracture, as well as antenna corrosion, electrostatic discharge, etc. Accelerated life testing is recommended before deployment when unusual environmental conditions are expected to determine any limitations on working life of the RFID-enabled label. These conditions may include outdoor storage; desert heat, arctic cold or freezer storage; nuclear or electromagnetic radiation exposure, chemical wash-down, etc.

4 Passive RFID-enabled media construction

This section discusses the materials and construction techniques used in making RFID-enabled labels and tie-on tags. As noted in Section [3.4](#), there are many factors that determine the appropriate design for a given application; whether that design will be environmentally compatible with the intended use, and have stable RFID performance over the required usage life. All of these factors affect media cost.

4.1 Basic RFID-enabled media configurations

4.1.1 Pressure-sensitive labels

Pressure-sensitive adhesives are widely used in RFID-enabled media. When properly chosen (see Sections [4.5](#) and [4.6](#)), these can meet both performance and environmental needs. [Annex A](#) contains basic terminology and key design parameters for RFID-enabled pressure-sensitive labels.

Normally, the transponder is attached to the facestock by the facestock adhesive, and the back of the transponder is adhesive coated as well to improve RFID-enabled label adhesion and prevent an air bubble from forming behind the transponder.

RFID transponders may be inserted into envelopes as an aid to transponder recovery and/or recycling (see Section [4.1.3](#) for envelope design guidance). The envelopes may be attached to the facestock and adhesive coated in a similar manner to direct attachment of a transponder, as above.

4.1.2 Dry-gum (water-activated) adhesive labels

These are *NOT* recommended for use in RFID-enabled media, because the water required for activation of the adhesive can have an impact on transponder performance. Water molecules attenuate UHF signals, so read range may be adversely affected. Added moisture may result in changing the conductivity of the adhesive, reducing antenna performance. Finally, added moisture may result in corrosion or chemical change in the properties of the antenna material or the chip bond.

4.1.3 RFID-enabled tickets used in carrier envelopes

RFID-enabled tickets can be inserted in paper or plastic envelopes. These envelopes may be directly attached to transport cases or pallets as a way of applying identification.

The envelopes should preferably be watertight once sealed. Envelope adhesives should preferably conform to the guidelines in Section 4.5; however this is less critical than in pressure-sensitive labels as the envelope adhesive is not in contact with the RFID transponder itself. The type of paper or plastic used for these envelopes should be both transparent to UHF radio waves and UV-resistant. Most types of polypropylene, polyethylene, PET and polyester films are reasonably low in attenuation at UHF frequencies. Polyvinyl Chloride (PVC) films should be avoided when with transponders with utilizing copper antennas due to potential long-term corrosion of the transponder antenna by the plasticizers.

4.1.4 Tie-on tags

Tie-on tags are RFID-enabled tickets that are attached with a tie-on. These are often used on non-conveyable material (see Section 9). Depending on the situation, a conductive wire tie-on may affect the transponder performance, positively or negatively. UV-resistant plastic (or other non-conductive) tie-ons are generally recommended for use with RFID-enabled tags.

4.2 Environmental considerations in media design

Many Commodity Classes of labeled material (including medicines and perishable food items) have highly restricted temperature ranges and operating life. In this case, the RFID-enabled label need only meet the environmental and working life requirements of the labeled material itself.

4.2.1 Operating and storage temperature ranges of applied RFID-enabled labels

For full-range military usage, however, the following recommendations apply.

Reading temperature range:	-40 to +70 °C	(-40 to +158 °F)
Storage range (non-reading)	-51 to +95 °C	(-60 to +203 °F)

4.2.2 Storage of RFID-enabled labels

New and partially-used RFID-enabled labels, like standard direct thermal or thermal transfer labels should be stored in a cool, dry environment sealed in anti-static (conductive) bags or cartons. This prevents water or other environmental damage; maintains paper moisture balance; prevents adhesive deterioration; and chip damage from electrostatic discharge. Temperature and humidity should be maintained within the limits of the manufacturer's specifications.

4.3 Label, ticket and tag printable facestocks

The facestock is the surface of the media that is to be printed. Paper and plastic facestocks may be used with RFID-enabled labels. Metal foil, metallized plastics, metal filled plastic, or high UHF attenuation plastics facestocks are not typically used in RFID-enabled labels as they interfere with RF communication with the transponder.

There are three key issues in selection of a label facestock: printing process compatibility (see Section 4.4); environmental compatibility with the intended label usage; and physical protection of the transponder from damage. Paper facestock is the lowest cost, but is the least environmentally resistant. UV-resistant plastic and plastic foam facestocks generally provide the best survivability in outdoor and rough service environments, and tend to provide the best protection for the transponder.

4.4 Printing method and ink compatibility

The type of ink or toner used must be matched to the type of printing process used, (see Section 5). The ink must also be matched to the selection of the label facestock material to assure good quality of the bar codes printed on the Military Shipping Label.

Environmental compatibility and long-term survivability of the printed image are key issues, especially for long-term or outdoor storage applications. Considerations include resistance to water damage, resistance to sunlight and UV-induced fading of the image, and image abrasion or smear resistance.

Most inks have little RF absorption. The supplier of the ribbon or ink should be consulted to ensure that there is no negative impact of printing on RFID performance. A simple test to determine if there is an impact of the ink on RF reading performance is to first measure the maximum reading distance of the unprinted RFID-enabled label (see [Annex C](#)). The label is then put through the intended printing process and the facestock is 100% printed with the intended ink. The maximum label reading distance is then re-measured using the same setup as before. If the maximum read range change is less than 10%, then the ink will have negligible impact on a normally printed (15-25% black) RFID-enabled label.

4.5 Permanent label adhesives

Label adhesives have two sets of properties that must be considered:

- “Initial tack” (ease of initial adhesion) and “settling time” (Number of minutes or hours it takes to form the full-strength permanent bond).
- Ultimate bond strength, i.e. long-term bond stability; environmental stability and aging resistance.

Most adhesives are primarily selected for the second set of properties. There are two basic adhesive families: Acrylic adhesives and rubber-based adhesives. While acrylic adhesives offer the widest range of properties and best high-temperature performance, rubber-based adhesives tend to be lower in cost, offer high initial tack and are often quite adequate for applications such as corrugated case labeling.

The physical and mechanical characteristics of adhesives to be used for RFID enabled labels must conform to MIL-STD-129 and MIL-PRF-61002 (see Sections [2.1.1](#) and [2.1.4](#) respectively). However, there are additional characteristics that relate to both RF properties and transponder compatibility that must also be considered in adhesive selection as covered in the following sections.

4.5.1 Adhesive RF properties and transponder compatibility

The adhesive, since it may be a complex chemical mixture and may also be in direct contact with the transponder antenna, can have strong effects on transponder performance. It may absorb RF energy. Chemical constituents of the adhesive may have a corrosive affect on the antenna (especially etched copper antennas). Also, many adhesives tend to chemically deteriorate with age so that while the adhesive properties may be perfectly acceptable at the time of initial RFID-enabled label application, after several months or years the effects of adhesive aging may affect the transponder performance. The supplier of the labels should be consulted to assure that the desired label working life is achieved.

4.5.2 Hygroscopic adhesives

Hygroscopic adhesives pick up moisture from the environment and incorporate it. This can result in a number of problems, including negative impact on RFID label performance and/or adhesive failure. Water molecules attenuate UHF signals, so read range may be adversely affected. Finally, added moisture may result in corrosion of the antenna material or the chip bond.

4.6 Removable label adhesives

Removable adhesives are usually not used with RFID-enabled labels as they may come off unexpectedly during handling. If a removable or repositionable RFID-enabled label is desired for special purposes, work with the label supplier to obtain the proper degree of adhesion and life for satisfactory results.

4.7 Release liners (backing) for pressure-sensitive labels

The purpose of a release liner is to carry the RFID-enabled label during its manufacture and handling to the point that the label is applied to the container.

4.7.1 Adhesive compatibility and release level

Adhesives and release liner coatings are matched to control the force necessary to peel the label from the release liner. Release force must be balanced: high enough so that the stiffer RFID-enabled labels nearest the roll core do not separate from the liner, and yet low enough so that the label will peel cleanly in the printer-encoder or label applicator.

4.7.2 Removing the RFID-enabled label from the release liner

A common cause of hidden damage to RFID-enabled label transponders is carelessness in manually removing the self-adhesive RFID-enabled label from its release liner. This is because the natural tendency is to peel the label from the liner, resulting in excessive stress and flexure of the transponder antenna, which can cause fracture of the antenna circuit or its bond to the RFID chip (see Section [3.4.1](#)). Figure 1A shows this undesirable practice.

Figure 1B shows a better manual method. Lay the RFID-enabled label face down on a flat surface, and peel the disposable release liner away from the RFID-enabled label. This minimizes flexure of the transponder.

Figures 1A-B. Incorrect and preferred method of peeling RFID-enabled labels

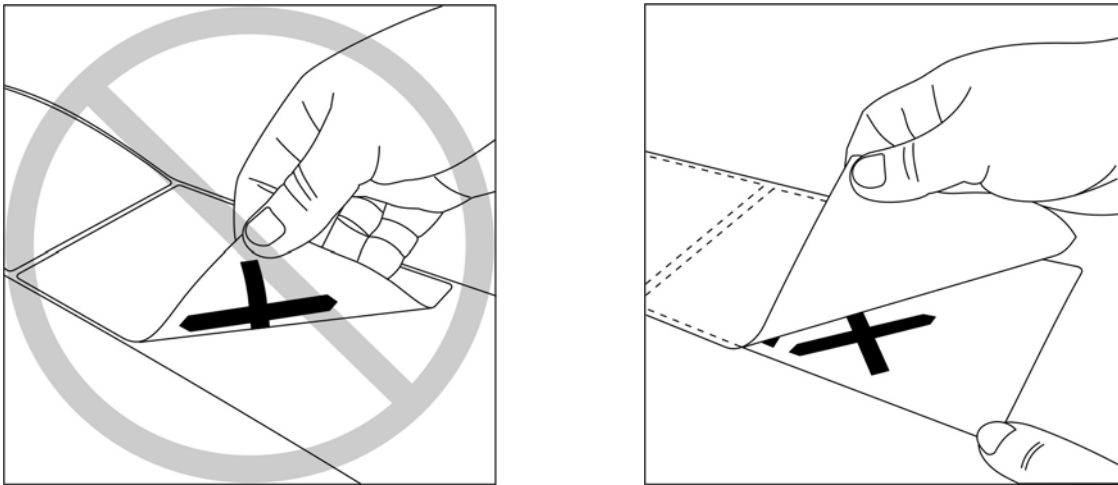

Printer encoders or label applicators with the capability of automatically stripping the release liner should be used at the point of label application whenever possible. These are designed to remove the release liner from the label with minimum flexure of the label.

4.7.3 RF properties of release liners

In practice, the RF properties of release liners are relatively unimportant, as the RFID-enabled label is removed from the release liner before usage on the container. One place that the RF properties are slightly important during label printing and encoding inside a printer-encoder. However, in this highly controlled environment, signal losses due to RF absorption can easily be compensated. In practice, a slight increase in RF loss due to conductive additives to the silicone to minimize the effects of electrostatic discharge during peeling (see Section [4.8.3](#)) may be a desirable tradeoff.

4.8 Avoiding electrostatic discharge (ESD)

Static electricity can easily be generated by many processes, including peeling the RFID-enabled labels from the release liner. It is especially a problem in low-humidity environments as found in desert, winter or high-altitude conditions. Discharge of static electricity through the transponder antenna into the RFID chip can cause permanent chip failure or loss or corruption of the stored data.

An often-unrecognized source of static electricity (especially in low-humidity environments) is the operator performing the label printing and application. A static charge can build up on the operator, which may be discharged through the RFID-enabled label as it is removed from the printer or applied to the case or asset. In dry environments and around hazardous materials, labeling operators should work in antistatic environments and wear antistatic clothing and protective gear.

RFID-enabled labels do not need to be more ESD resistant than the objects that they label. The recommended level of ESD compliance, and a practical compliance testing method based on MIL-STD-464 (see Section [2.1.5](#)) are given in Section [4.8.5](#).

4.8.1 Transponder antenna design considerations

Figure 2 shows partial detail around the chip of two antenna designs having superior ESD resistance. Note the presence of a DC short between the antenna terminals attached to the integrated circuit. This type of antenna design is to be preferred for ESD resistance.

Figure 2 – Antenna design details showing DC shorts for superior ESD resistance

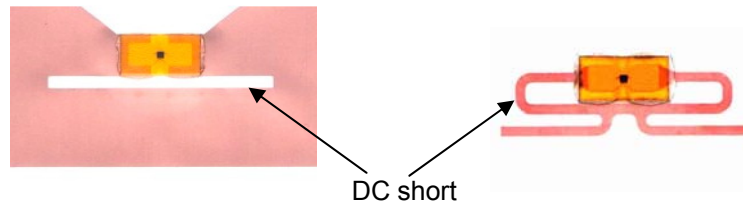

4.8.2 Printer-encoder considerations

There are two common sources of static electricity generation in printer-encoders: That caused by unwinding or unstacking the facestock, and that arising from unwinding the ribbon (when present; see [4.8.2.1](#)). Especially in low humidity environments, a static charge can build up on the label from either source that can discharge into the chip and damage or destroy it. The solution is to safely dissipate the static electricity without damaging the RFID chip. The design of the printer-encoder should eliminate this source of RFID-enabled label damage.

There are special ESD considerations for certain types of RFID-enabled label, ticket and tag printer-encoders.

4.8.2.1 ESD in thermal transfer printers

Thermal transfer ribbons used in many label printers generate static electricity as the polyester film unwinds from the ribbon supply roll. This appears as opposite charges on both sides of the ribbon. Especially in low humidity environments, ensure that the printer has either metal contact or antistatic brushes on the inked side of the ribbon so that the static charge is not dissipated by ESD into the transponder antenna during printing.

4.8.2.2 ESD in Laser and LED printers

The electro-photography methods used in these printers rely on an electrostatic charge on a drum or belt to attract and hold the toner while it is fused to the label stock under heat and/or pressure. These electrostatic processes can contribute to RFID-enabled label failure through ESD. Typically, there may also be mechanical failures in desktop laser printers from bending the label over small internal rollers (see Section [3.4.1](#)). This type of printer should be tested extensively for RFID-enabled label damage before deployment, especially in low humidity environments.

4.8.3 Peeling as a source of static electricity

Peeling the RFID-enabled label from release liner (see Section [4.8.3](#)) is a common source of static electricity generation. This occurs whether the label is peeled manually or within a printer or label applicator mechanism. Most printers and applicators have internal methods for safely dissipating the static electricity.

4.8.4 Conveyors as sources of static electricity

Rubber conveyor belts can build up static electricity as a result of their motion and rubbing against surfaces. This static charge can be transferred to the labeled object causing RFID label damage. The best way to avoid this is by designing or modifying the conveyor system to avoid static electricity build up.

Consulting with the conveyer supplier should provide a way to have the static electricity tested and, if found, eliminated.

4.8.5 ESD compliance testing

Electrostatic discharge is clearly a safety issue around explosives, hazardous chemicals and chemical fumes. MIL-STD-464 Section A5.7.3 ESD compliance requirements (see Section [2.1.5](#)) for ordnance subsystems are based on static electricity charge levels that could possibly be developed on personnel to guarantee safe ordnance handling:

“Ordnance subsystems shall not be inadvertently initiated or dudged by a 25 kilovolt electrostatic discharge caused by personnel handling”

Compliance with this requirement is therefore recommended for RFID-enabled labels as well, in both ordnance and non-ordnance related applications.

Compliance shall be verified by test such as MIL-STD-331, or simply by discharging a 500-picofarad capacitor charged to 25 kilovolts DC through a 500-ohm resistor. The 500-picofarad capacitor and 500-ohm resistor simulate the characteristics of a human body discharge. During testing, circuit inductance should be limited to 5 microhenries. The discharges must be applied in both polarities at various points on the RFID-enabled label as applied to the intended packaging placed on a grounded metal plate

A statistically significant number of RFID-enabled labels on packaging should be tested to provide a scientific basis for concluding that the requirement is met.

5 Printing and encoding RFID-enabled labels

5.1 Printing methods

RFID-enabled labels often contain unique printed information, which is correlated with the unique encoded data in the transponder. This may be performed in a single step through use of a printer-encoder. Using a single-step process, (rather than printing and encoding the data separately) ensures that the printed human-readable, bar codes and the encoded transponder data exactly correlate, both with each other and the database record for the labeled item. Ensure that the RFID-enabled label design, transponder selection and placement in the label (see [Annex A](#)) match the printer-encoder used.

Printer-encoders designed to encode at a minimum the 96-bit EPC data structures GRAI-96 (see Section [7.1.2](#)), SSCC-96 and SGTIN-96, and the DoD UID-96 (see Section [7.3.2](#)) in RFID enabled labels may carry the AIM RFID Mark “M*” as specified in [Annex B](#).

5.2 Label edge start sensing issues

Printer-encoders generally sense either the leading edge of the label facestock; a printed black mark on the back of the label release liner; or a notch or hole. Ensure that the RFID-enabled label stock and printer-encoder method are correct for each other. Also see that the label registration sensor has been calibrated against the label stock in use.

5.3 Encoding and/or verifying transponder data

Most printer-encoder systems test the transponder both before and after encoding to verify that the transponder is both functional and that the data was properly encoded. Use of any method or equipment to encode RFID-enabled labels that does not perform this validation should be avoided.

5.4 Dealing with defective transponders

Printer-encoder systems that test the transponder to verify that the transponder is both functional and the data properly encoded also generally identify labels with defective transponders by printing special marks

(such as “void”) on the defective labels. These labels should be disposed of, either manually or automatically, and not used for labeling.

Most of these same printer-encoders will then attempt to encode and print the same information on next RFID-enabled label automatically, until successful.

When serialized labels are to be prepared, it is recommended to print the label serial number with the same label format program that controls the RFID encoding process. This generally ensures that serial number sequencing is not lost when bad RFID-labels are encountered, and are then reprinted and reprogrammed on the next label.

6 RFID-enabled label placement and attachment

6.1 RF influence of the package and its contents on the transponder

At UHF frequencies, packaged objects and packaging materials respond in different ways to the presence of radio waves at different frequencies. Since many non-metallic packaging materials are permeable to UHF frequencies, the RF properties of the contents affect the transponder performance, even when the transponder is placed on the outside of the package. A simple view is that materials and objects may be RF transparent, RF signal reflecting or RF signal absorbing.

- Typically, the effect of conductive RF reflecting materials is to shield or detune the transponder antenna from its resonance frequency so that the antenna can no longer absorb enough RF energy to activate the transponder chip, allowing to it turn on and backscatter data back to the reader
- Absorbing materials reduce the signal to the transponder by dissipating the RF energy from the reader, causing less energy to be available to power up the chip.
- Chemical composition of an object can result in mixed properties of reflection and absorption

Many objects are a mixture of these properties. Figure 3 shows a triangular graph of the properties, each ranging from 0 to 100%.

Figure 3 – RF properties of some corrugated cases containing various objects

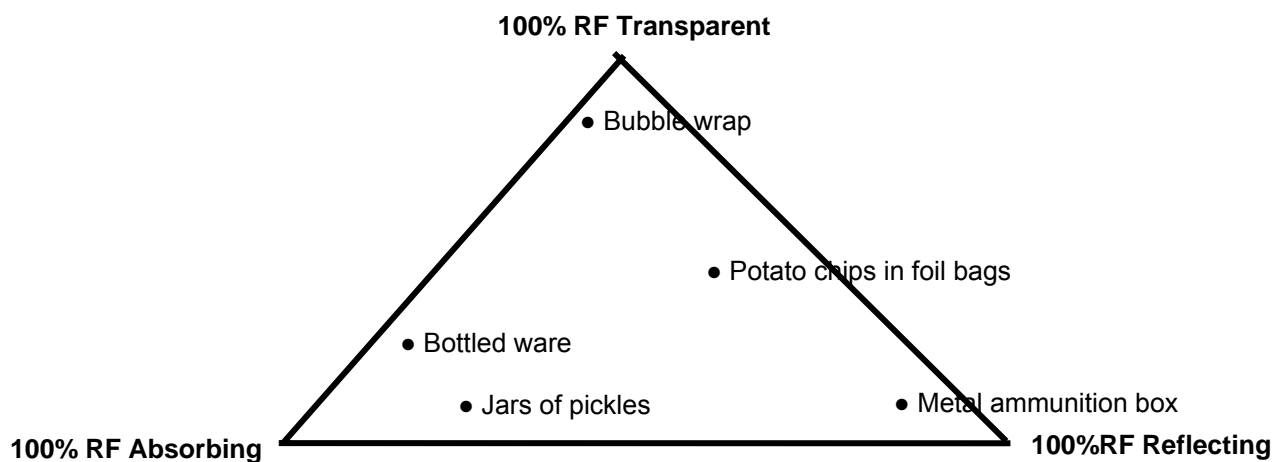

Imagine a UHF RFID reader with its antenna placed just above the surface of the case where the transponder would be placed at a series of corrugated cases each containing one type of object. Some basic observations:

- Note that the peak of the triangle implies that the package is virtually RF transparent; RF energy is neither absorbed nor reflected. Bubble wrap is only a slight RF absorber.
- Metal objects, like the ammunition box, are high in RF reflectance but low in absorption.
- Water is a high RF absorber at UHF, but a low RF reflector.
- The pickles in glass jars are excellent RF absorbers, because they contain electrolytes (salt and vinegar) and well as water, but the metal lids are also RF reflectors.
- The foil bags of potato chips reflect the RF, but because of the non-uniform surface shape also scatter it in directions other than the incident direction. Thus some reflected energy is lost by the package scattering it in random directions.

The fundamental point of the pyramid graph is that the higher the package scores on the pyramid, the less the package influences the reading of the transponder. Qualitatively, those packages should generally have the longest read range.

One positive way to establish that an RFID-enabled label works properly on a given type of container is to have a third party test laboratory test and certify it. Alternatively, in-house testing using the simplified methods and apparatus of [Annex C](#) will allow a selection of the type and placement of RFID-enabled label to achieve reasonable transponder read range performance. However, many packages can be evaluated using a common-sense visual analysis.

6.2 Visual inspection method for determining label placement

Most packages (especially if they contain irregularly shaped metal objects) have a mixture of RF reflective and absorbing properties, which are not uniform across the surface of the package. Often, the RF properties are better near the edges. In the example in Figure 4, assume a round metal bucket is packed in a corrugated case, with the top and bottom of the metal bucket nested top and bottom in molded rigid foam; and the middle of the package is open (air). Figure shows a cross-section of the packaged bucket.

If RFID enabled labels are placed at points A-F on the surface of the case, their relative RF properties due to the influence of the object and its packaging (measured as described above) are shown in Figure 4. This Figure 4 reflects a qualitative rating of their estimated RF properties from looking at the package.

Figure 4 – RF properties map for a corrugated case containing a metal bucket

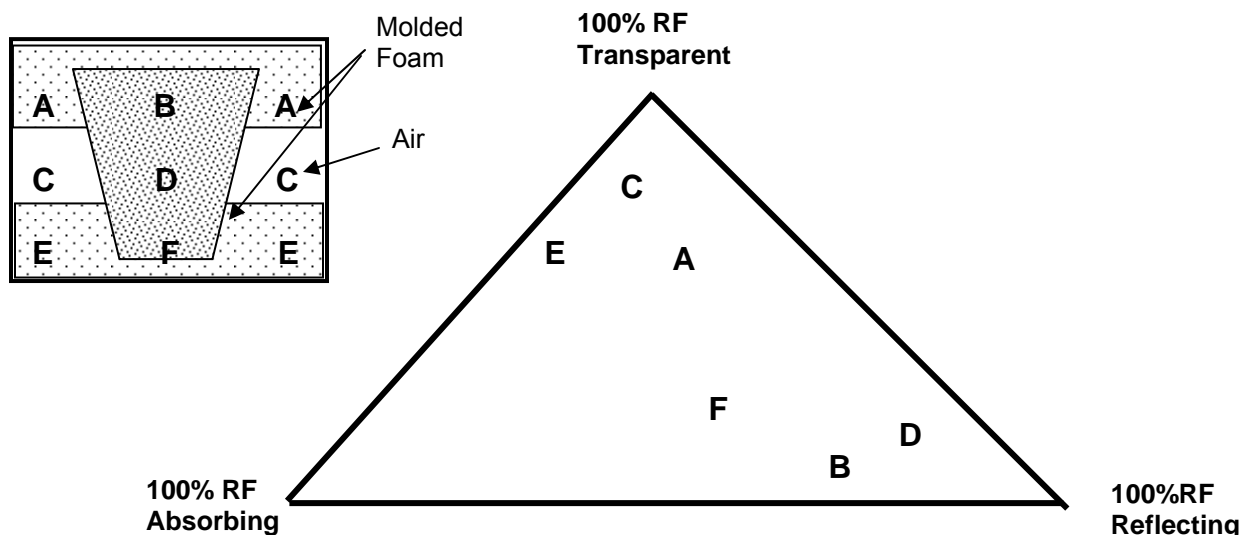

A UHF reader interrogating RFID-enabled labels at points A-F sees different RF properties at different places. In this illustration, the molded foam is RF absorbing while the bucket itself is RF reflecting.

- Point C would experience a small reflective effect from the nearby curved bucket, and little absorption as there is no foam in the area, just air.
- Points A and E would have equal amounts of signal absorption from the full thickness of molded foam, with point A having a larger reflective component as the bucket diameter is larger at the top than the bottom, and thus closer to points A.
- Point B has the bucket closest to the surface, and thinner foam than point F, so point B is more reflective and has less RF absorption than point F.
- Point D has the bucket further from the surface than point B and has no foam covering it (only air), so it will have both less RF reflection and less RF absorption than point B
- The likely best place for an RFID enabled label is point C, as it has the least influence from the packaged bucket.

This gives rise to the rule: "*Climb the pyramid*" to determine the best label placement

6.3 Transponders for objects primarily acting as RF reflectors

Typically, the effect of reflective objects or metal surfaces is to detune and/or shield the transponder antenna so that the operational range is reduced.

One approach to minimize this impact is to conduct tests to find the place on the package surface where the least amount of reflection occurs, and then determine whether acceptable read range performance can be obtained with a standard transponder located in that position. It is also not unusual, however, for some reflective material in the case to actually improve the performance of a standard transponder by increasing the backscatter signal in certain directions (See [Annex C](#) for test methods).

Another approach is to use a transponder specially designed for use on reflective surfaces. These typically use the corrugate itself as a spacer or have an additional foam spacer below the transponder together with a designed resonance frequency so that the effect of the reflective surface is to *retune the transponder's resonant frequency toward the reader frequency*. In combination with proper placement, specially designed and constructed transponders can often overcome the problems of reflective objects.

6.3.1 Dielectric spacer materials and design considerations

Many military objects are packaged in metal containers. One way of improving the reading performance of the specially tuned transponders designed for reflective surfaces is to use a corrugate, plastic, foam or plywood underlabel. Even a few millimeters of separation between the metal object surface and the transponder (such as the thickness of the wall of the corrugated case itself) may result in dramatically improved read range, depending on the combination of spacer thickness and transponder selection.

6.4 Transponders for objects primarily acting as RF absorbers

Highly absorbing materials like liquids tend to absorb the RF energy from the reader before it reaches the RFID-enabled label, and they can also detune the antenna. Both of these effects render containers of liquids or other RF absorbing materials difficult for RFID labeling.

One approach is to conduct tests to find the place on the package surface where the least amount of absorption and detuning occurs, and then determine whether acceptable read range performance can be obtained with a standard transponder located in that position. See [Annex C](#) for test methods. Special transponders are also available for use on RF-absorbing objects. In combination with proper placement, special transponders can help to overcome the problems of most RF-absorbing objects.

6.4.1 Isolation using reflective underlabels

One approach to extend the read range for highly RF-absorbing packages is to apply a metal foil or metallized plastic label to the inside of the corrugated case behind the transponder. Alternatively, a foil or metallized spacer sheet may be inserted between the corrugate wall and the object. This isolates the transponder environment from the RF absorber. Then, RFID-enabled labels with transponders designed for reflective surfaces then may be more effective choice, as discussed in Section [6.3.1](#).

6.5 Some common packaging problems

For product cases containing paper and/or plastic products, most RFID labels can be placed in a variety of locations on the case. Usually, the label ends up being placed in an area where it does not cover up any logo or processing lot control information stamped on the case.

For product cases containing liquid product, it's best to place the RFID label as far away from the liquid as possible. Therefore, depending on how the liquid containers are designed and stacked within the case, a specific top or side corner of the case may have to be utilized.

- In cases containing cylindrical cans, consider RFID enabled labels with vertically polarized dipole antennas placed either over the gap between the curved containers or near a vertical corner of the case. The best result is usually obtained by placing the transponder as close to the edge of the case as possible.
- Necked bottles often create a substantial air space at the top of the case. RFID enabled labels with horizontally polarized dipole antennas placed near the top of the case may be good choice.

See Sections [6.4](#) and [6.4.1](#) for additional ideas. See [Annex C](#) for test methods

Product cases containing tightly-packed metal products, such as a case of canned drinks, pose a real challenge. Many of these cases are not full corrugated cases at all: Instead, the corrugate is in effect a tray that the soda sits in and then a clear plastic stretch material covers the contents. For this situation, long narrow-width RFID transponders may be physically required so that they fit on the corrugated tray. The label application area is limited, and the transponder antenna may cross over many cans. Labels designed for use with reflective package contents work best here (see Section [6.3](#)).

7 RFID labeling of conveyable cases and containers

This section deals with RFID-enabled label placement on the conveyable cases, totes and other objects in that location that will provide the most reliable transaction communications between the RF-enabled label and the reader.

7.1 Definition of a conveyable object

Conveyable objects are designed for transport on rubber belt or roller conveyors. Most transport packages are conveyable objects. Conveyable objects typically conform to the following commercial specification:

- Minimum specifications:
 - 22,5 cm (9 in) long; 10,0 cm wide (4 in) wide; 7,5 cm (3 in) tall; weight \geq 1.8 kg (4 lbs)
- Maximum specifications:
 - 122 cm (48 in) long; 63,5 cm (25 in) wide; 101 cm (40 in) tall; weight \leq 24.6 kg (55 lbs)
- Packages cannot have protrusions, plastic or metal banding on the outer packaging
- Packages cannot be round or irregularly shaped
- Packages must be tightly sealed; flaps must remain secure during material handling
- Hazardous materials and liquids must not leak out if the case is damaged or broken
- Outer packaging material may be corrugate, wood, metal, rigid or heavy-gauge flexible plastic

7.1.1 Transport packages (cases and cases)

A transport package is considered to be a package intended for the transportation and handling of one or more articles, smaller packages, or bulk material. MIL-STD-129 (see Section [2.1.1](#)) requires that the Military Shipping Label be on the longest side of the package.

Figure 5. Recommended transponder location on transport packages

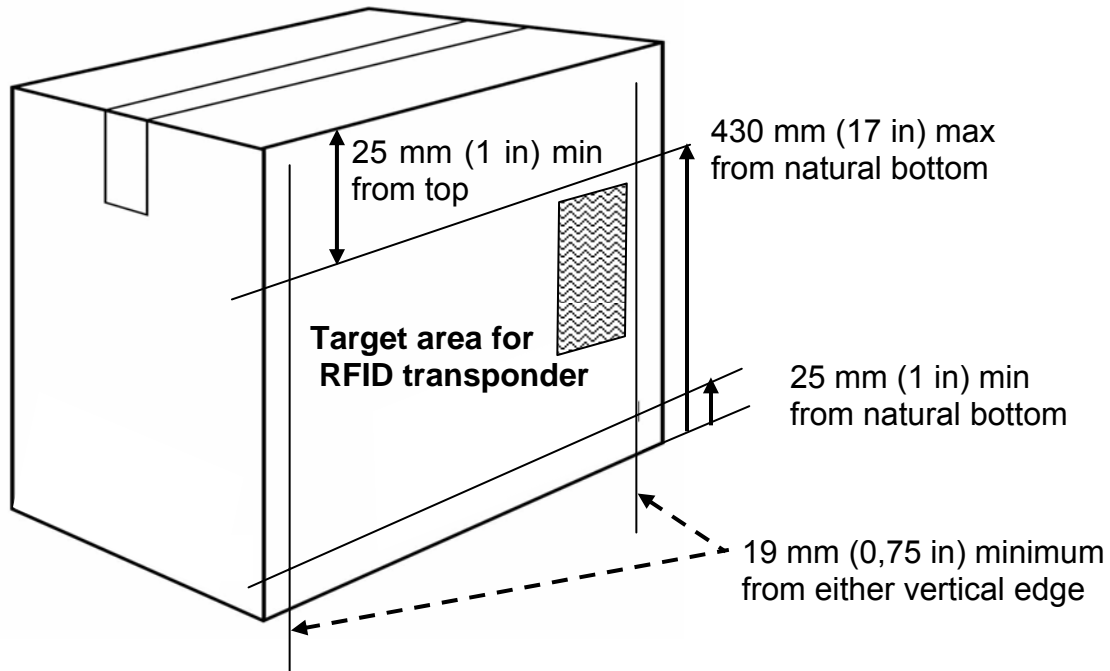

7.1.1.1 Recommended RFID-enabled label placement

The following recommendations address *transponder* placement, even if separate from the Military Shipping Label. For transport packages from 200 mm (8 in) to 1 m (40 in) in height, it is recommended that the transponder itself or the transponder in the RF-enabled label should be placed as shown as in Figure 5:

- The bottom edge should be no closer than 25 mm (1 in) from the natural bottom of the package
- The top edge should be no farther than 430 mm (17 in) from the natural bottom of the package, but no closer than 25mm (1 in) from the natural top of the package.
- Neither vertical edge of the label shall be closer than 19mm (0.75 in) from a vertical corner.
- Antenna polarization preferably shall be oriented to provide maximum read range under the guidance of Section [6](#) and/or [Annex C](#), assuming a circularly-polarized reader

RFID-enabled media on these transport packages should be placed in a location within the target area that provides the most reliable RFID communication between the media and the reader, using the guidance of Section [6](#) and/or [Annex C](#). Placement of transponders at case corners or edges is not recommended, as these areas frequently suffer damage during material handling.

For transport packages greater than 1 m (40 in) in height, follow the recommendations of Section [8.2.1](#).

For transport packages less than 200mm (8 in) in height, it is recommended that the unique RF-enabled label should be placed on top of the package.

7.1.1.2 Read range performance requirement

The transponder selection and placement shall provide a read range of at least 1 meter (40 in) with conveyor speeds up to 200 meters per minute (600 feet per minute) at the maximum allowed radiated reader power in the radio regulatory environment in which it was designed to be used.

7.1.2 Reusable plastic totes, delivery trays, etc.

Owners of reusable shipping containers intended for use on conveyors may wish to permanently install RFID transponders on these containers to facilitate their tracking and return to the owners. The EPC Tag Data Standards (See Section [2.4.4](#)) specify a 96-bit data structure called the Global Returnable Asset Identifier (GRAI-96) that should be used for this purpose and permanently encoded in these permanent transponders. If a transponder utilizing GRAI-96 is used, it is in addition to the required Military Shipping Label and its required transponder structure as specified in Section [7.3.2](#).

In general, permanent asset identifier transponders containing GRAI-96 data should be mounted on the container following the same guidelines in Section [7.1.1](#) as for the transport package label, within the placement limitations specified in Section [7.4](#). When multiple GRAI-96 tags are used on different sides of a returnable container to identify it, each transponder will contain identical data.

7.1.3 Other conveyable goods

Bags, bundles, fiber and plastic drums, etc. may be conveyed if they meet the guidelines in Section [7.1](#); are rugged enough to withstand abrasion or damage by the conveyor; and do not have loose objects straps or protrusions that can get caught in the conveyor. RFID-enabled labels or tie-on tags should be placed so that when the bag or bundle is on conveyor, the label is on one side of the unit, or facing upward, with the printed surface visible.

7.2 RFID reader assumptions

Typical on-conveyor reader systems use multiple antennas. As few as two wide-field antennas on opposite sides of the conveyor when cases are oriented with the RFID enabled label always on the side and the natural case bottom rides on the conveyor. As many as six antennas may be used to read all sides of a randomly oriented case as it passes through the multiple antenna fields. Since reader RF power is determined by local radio regulations, the number, placement and field width of the antennas is also affected by the available reader power.

It is strongly recommended that the reader antennas be circularly polarized, and therefore equally capable of reading polarized antennas (such as UHF dipoles) placed in any orientation within the plane of the RFID-enabled media that is reasonably perpendicular to the path to the antenna.

Readers designed to read at a minimum the 96-bit EPC data structures GRAI-96 (see Section [7.1.2](#)), SSCC-96 and SGTIN-96, and the DoD UID-96 (see Section [7.3.2](#)) may carry the AIM RFID Mark "M*" as specified in [Annex B](#).

7.3 Label format and transponder data structure

7.3.1 Printed label format

The printed label format should correspond to MIL-STD-129 with the addition of:

- Either an EPCglobal logo or the AIM RFID Mark as shown in [Annex B](#) containing the two-character code appropriate for the DoD or EPCglobal data structure in use should be printed.
- The addition of a data element at the end of the data structure contained in the existing PDF-417 bar code on the Military Shipping Label starting with the Data Identifier "96S" and followed by a 24-character ASCII hexadecimal string representation of the appropriate 96-bit binary data structure.

- Human readable representation of the 96-bit transponder data structure, printed as either:
 - A 24-character ASCII hexadecimal string representation of the 96-bit data structure encoded in the bar code (*interim and not preferred solution*)
 - A 28-character ASCII hexadecimal string representation of the 96-bit data structure encoded in the bar code preceded by that of its 16-bit ISO 13239 CRC-16 check value (*preferred solution*).

7.3.2 Transponder data structure

Either an EPCglobal or DoD 96-bit data structure is to be used depending on:

- The contract terms of the DoD supplier for goods initially received by DoD,
- Internal applications standards within the DoD supply chain.

7.3.2.1 EPCglobal data structures

These are defined in the EPCglobal Tag Data Standards (See Section [2.4.4](#)).

When the conveyable unit contains either:

- A predefined number of a identical commercial objects (ex: 24 cans of peas), or
- A standard assortment or kit (e.g.: a set of dishes or tools; a partially-assembled bicycle),

It generally is called a stock-keeping unit (SKU) and has associated with it a Global Trade Item Number (GTIN). If a single GTIN accurately represents the entire contents of the package, then the EPC Tag Data Standards (See Section [2.4.4](#)) specify that the Serialized GTIN data structure SGTIN-96 is to be utilized. SGTIN-96 RFID-enabled labels should be locked so that they will not be reprogrammed.

If the conveyable unit contains either:

- A non-standard assortment of objects or objects with multiple GTINs (ex: 2 cans of motor oil, a box of cereal, and a calculator)
- A non-standard number of identical commercial objects (ex: a partial case of 17 cans of peas)

then the Serialized Shipping Container Code data structure SSCC-96 is to be utilized.

7.3.2.2 DoD data structures

One of two DoD 96-bit data structures may be used:

- UID Unit Pack: Used on item packaging meeting the DoD criteria for assignment of UID (“Unique Identification”; see Section [2.1.6](#))
- DoD Case or Pallet: Items shipped as either pure or mixed case or pallet

The DoD 96-bit data structures are constructed as follows:

Header	Filter	DODAAC/CAGE	Serial Number
8 bits	4 bits	48 bits	36 bits

Header: Header value 2F_{hex} (binary value 0010 1111) indicating that this is a DoD-defined tag data structure defined within the EPCglobal Numbering System Identifier system

Filter: Identifies whether the object is a pallet, case or UID-identified item:

- 0000 – Pallet
- 0001 – Case
- 0010 – UID identified item
- All other 4-bit combinations are reserved

DODAAC/CAGE: Six 8-bit ASCII characters that identifies the supplier and ensures uniqueness of serial number across all suppliers.

Serial Number: Thirty-six bit binary serial number that identifies up to 68,719,476,736 unique items. DoD 96-bit data structures:

- UID Unit Pack: Used on item packaging meeting the DoD criteria for assignment of UID
- DoD Case or Pallet: Items shipped as either pure or mixed case or pallet

7.3.3 Use and reuse of the SSCC-96 transponder

An SSCC-96 is intended as temporary identification corresponding to a single trip within the transport function between consignee and consignor with a 1-year maximum assignment life. Different SSCC-96 data structures are therefore assigned to each trip. It is the intent that the SSCC-96 RFID-enabled label will be unlocked and re-programmable to reflect the tracking information required in subsequent uses.

RFID-enabled labels shall never be placed one on top of another:

- When over-labeling a reprogrammed SSCC-96 label is performed, a non-RFID enabled (plain) label containing the human readable, bar code and the “E2” AIM RFID Mark information (see [Annex B](#)) shall be used to over label the reprogrammed SSCC-96 RFID-enabled label.
- If the existing SSCC-96 RFID label is unable to be reprogrammed, the old RFID-enabled label shall be removed and replaced with a new SSCC-96 RFID-enabled label.

7.4 Use of multiple RFID-enabled labels

While an SSCC-96 is intended as temporary identification corresponding to a single trip, an SGTIN-96 is intended to permanently identify the product contained within case.

There may be benefit to encode both SGTIN-96 and SSCC-96 transponders in the situation that a case labeled with an SGTIN-96 may be reshipped from the consignee to a new consignee or when the case is returned by the consignee to the consignor. When using both data structures, two separate tags, one encoding an SGTIN-96 and another encoding an SSCC-96, should be affixed.

When multiple EPCglobal 96-bit RFID-enabled labels are attached to the same case (e.g., an SSCC-96 and an SGTIN-96; or an SSCC-96 and a GRAI-96), the separation between the transponders shall be no closer 10 cm (4 in). If the transport container is so small that one side will not support such separation, then another side of the container shall be used for the second label. The printed label formats should follow the recommendations of Section [7.3.1](#).

8 RFID labeling of palletized unit loads

Both RFID-enabled media and permanently attached RFID transponders may be used—separately or together—with pallets and palletized unit loads. For example, the pallet itself may have one or more permanently attached RFID transponder(s) to aid in the tracking of the pallet itself, while the unit load on the pallet may have a RFID-enabled shipping label.

A unit load is considered to be one or more transport packages or other items held together by means such as pallet slip sheet, strapping, interlocking, glue, stretch wrap, shrink wrap, or net wrap, making them suitable for transport, stacking, and/or storage as a unit.

8.1 RFID reader assumptions

The pallet and/or unit load transponders will typically be read at different points in pallet handling with a variety of UHF RFID readers. Therefore, transponder selection and placement must be made to accommodate all the reader types discussed below.

8.1.1 Portal readers

Portal RFID readers are typically fixed gate or bridge readers used at dock doors to automatically read the labels of pallets and unit loads passing in either direction through that door. They also may be temporary gate readers brought to a location to facilitate unloading of a rail car, truck or container. Their function is to read unit load transponders, regardless of the orientation of the transponder relative to the reader, as long as the transponder is not up against a metal surface such as a forklift truck structure.

8.1.2 Forklift-mounted readers

Forklift readers may have multiple antenna structures to allow reading of pallet and/or unit load labels while carried by the forklift truck. There may be a requirement for alignment of the unit load label and the forklift reader antenna, to assure reliable operation of the RFID data system. This data is typically wirelessly connected to a host computer.

8.1.3 Pallet conveyor readers

Pallet conveyor readers are typically fixed-mount devices similar to the transport package conveyor readers discussed in Section [7.2](#). They typically are short-range devices with a read range under 1 meter (less than 3 ft) and a limited angle of view. To accommodate the limited field of view, the unit load RFID-enabled label or fixed transponder is placed within a fixed band relative to the bottom of the pallet. See Section [8.2](#) below for details.

8.1.4 Handheld readers

Handheld readers are often used for material handling operations at the pallet level, typically for reading the unit load label and either recording the data in a personal data terminal, and/or wirelessly communicating the data to the reader's host computer. Handheld readers are widely used in reading material once deployed in the field.

Handheld readers are usually low power, battery-operated devices with a read range more limited than typical portal readers. They may be integrated with bar code readers and/or a personal data terminal. A key requirement is that the user brings the reader close enough to the transponder for it to read reliably.

8.2 RFID-enabled label usage and placement on pallet unit loads

Each pallet shall have at least one unit load RFID-enabled label. Unit load tracking should utilize an RFID-enabled Military Shipping Label (MSL) encoded with an appropriate 96-bit data structure corresponding to Section [8.2.2](#). The printed label format should correspond to Section [7.3.1](#).

8.2.1 General rules for unit load RFID-enabled label location

These general rules for transponder placement parallel the rules for bar code labels in ISO 15394(E):2000 (see Section [2.5.1](#)). While it is recognized that the transponder (RF tag) will generally be integral with the Military Shipping Label (RFID-enabled MSL), the following recommendations address transponder placement, even if separate from the MSL. Referring to Figure 6:

- RFID-enabled labels should be placed on the long side of the transport unit with the human readable information parallel to the natural bottom of the transport unit.
- The RFID-enabled label shall be placed right of center on a vertical face, allowing a minimum of 5 cm (2 in) from all edges to prevent transponder damage during material handling.
- The bottom edge of the tag containing the unit load information should be within the range of 81 cm to 122 cm (32 to 48 in) from the bottom of the pallet. If the pallet is less than 51 cm (20 in) in height, the label should be placed as high as possible on the pallet, but not closer than 5 cm (2 in) to the natural top of the unit load.
- The label should not be placed over a seam nor should sealing tape or bands be placed over the label in a manner that interferes with the scanning of the label bar codes or reading the transponder data.
- If the pallet is shrink-wrapped or stretch-wrapped, the RFID-enabled label shall be affixed on the *outside surface* of the wrapping, and not covered by it.
- The RFID-enabled label should not be placed in a manner that overlaps any other existing RF transponder. There should be at least a 10 cm (4 in) separation between transponders.
- Labels should be affixed at a suitable location where there is a minimum risk of damage.
- Label material shall be environmentally compatible with the conditions of shipment and storage of the unit load.

Figure 6. Unit load RFID-enabled label position on a palletized load

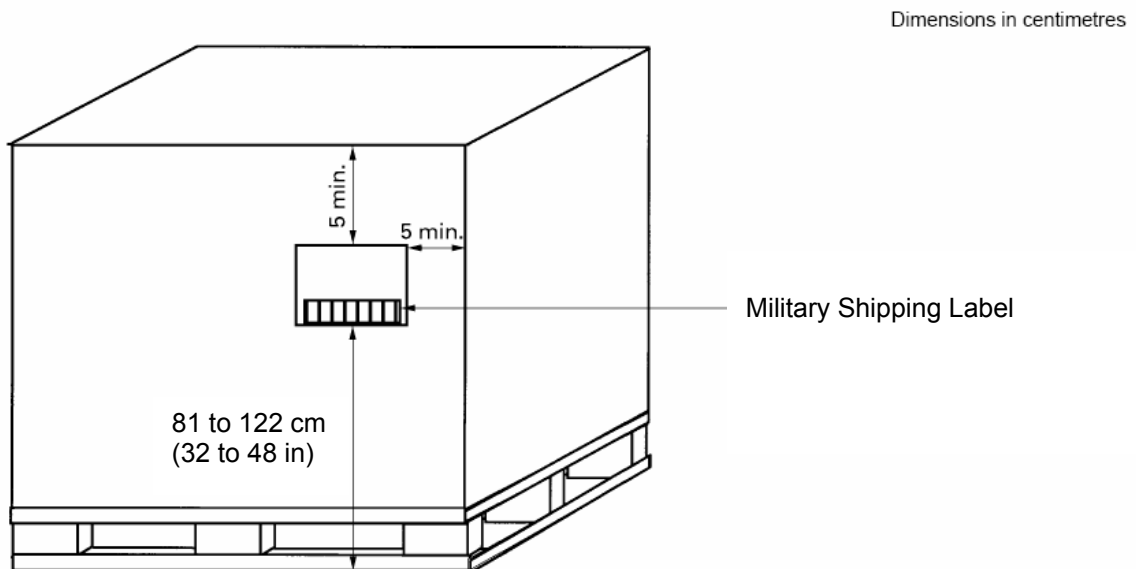

The selection and placement of the RFID-enabled label shall be such that the transponder, as positioned and mounted on the unit load, has a read range of at least 3 meters (10 ft) when no obstructions are present between the label and a portal reader) at the maximum allowed radiated reader power in the regulatory environment for which it was designed to be used.

Linearly polarized, circularly polarized, or omni-directional transponders may be used as long as the read range requirement is met.

8.2.2 Transponder data structure

Depending on

- The contract terms of the DoD supplier for good initially received by DoD,
- Internal applications standards within the DoD supply chain,

either an EPCglobal or DoD 96-bit data structure is to be used.

8.2.2.1 EPCglobal data structures

These are defined in the EPCglobal Tag Data Standards (See Section [2.4.4](#)). Normally, the Serialized Shipping Container Code data structure SSCC-96 is utilized. Normally, the SSCC-96 transponder is left unlocked for reuse (see Section [7.3.3](#)).

In the infrequent case that the unit load itself is a single stock-keeping unit (ex: a palletized refrigerator; exactly 24 cases of light bulbs) and has associated with it a predefined Global Trade Item Number (GTIN), then the Serialized GTIN data structure SGTIN-96 may be utilized. RFID-enabled labels containing an SGTIN-96 data structure should be locked so that they will not be reprogrammed.

8.2.2.2 DoD data structures

One of two DoD 96-bit data structures may be used:

- UID Unit Pack: Used on unit loads meeting the DoD criteria for assignment of a UID (“Unique Identification”; see Section [Clive Hohberger, Ph.D. 2.1.6](#))
- DoD Pallet: Items shipped as either pure or mixed pallet

The DoD 96-bit data structures are constructed as follows:

Header	Filter	DODAAC/CAGE	Serial Number
8 bits	4 bits	48 bits	36 bits

Header: Header value $2F_{hex}$ (binary value 0010 1111) indicating that this is a DoD-defined tag data structure defined within the EPCglobal Numbering System Identifier system

Filter: Identifies whether the object is a pallet, case or UID-identified item:

- 0000 – Pallet
- 0001 – Case
- 0010 – UID identified item
- All other 4-bit combinations are reserved

DODAAC/CAGE: Six 8-bit ASCII characters that identifies the supplier and ensures uniqueness of serial number across all suppliers.

Serial Number: Thirty-six bit binary serial number that identifies up to 68,719,476,736 unique items.

DoD 96-bit data structures:

- UID Unit Pack: Used on item packaging meeting the DoD criteria for assignment of UID
- DoD Pallet: Items shipped as either pure or mixed case or pallet

8.2.3 Wooden and plastic pallets

It is assumed in this case that the unit load RFID-enabled label is placed on the unit load carried by the pallet. Permanent RFID transponders with GRAI-96 data structures may be mounted on the pallets themselves without limitation to facilitate their tracking and return to the owners.

8.2.4 Special considerations for bin, cage, and tub pallet containers

When the unit load is contained within a metal or plastic cage, bin or tub, as shown in Figure 7, use of a hanging RFID-enabled tag attached to the pallet container may be optionally used in place of attaching the RFID-enabled label to the container itself. When a unit RFID-enabled label is attached directly to the pallet container, it shall meet the same read range performance requirements of Section [8.2.1](#).

When a hanging unit load RFID-enabled tag is used, its natural rest position shall be that it is flat against the vertical pallet container wall with the printed side facing outward. Use of a non-metallic tie-on is recommended (see Section [4.1.4](#)). The selection of the transponder used in the RFID-enabled tag shall be such that when placed in the hanging rest position, the tag has a read range performance requirements of Section [8.2.1](#) when no obstructions are present between it and a portal reader.

Linearly polarized, circularly polarized, or omni-directional transponders may be used as long as the forgoing requirements are met.

Figure 7. Optional unit load RFID-enabled tag usage on pallet containers



8.3 Permanent RFID labeling of pallets

Pallet owners and pallet rental companies may wish to install permanent RFID transponders on the pallets to facilitate their tracking and return to the owners. The EPC Tag Data Standards (See Annex A, Section [2.4.4](#)) specify a 96-bit data structure called the Global Returnable Asset Identifier (GRAI-96) that should be used for this purpose and permanently encoded in the permanent pallet-tracking transponder.

If a transponder utilizing GRAI-96 is used, it is in addition to the required unit load RFID-enabled label and its required transponder structure as specified in Section [8.2](#).

In general, permanent transponders may be mounted in the pallet structure in either the geometric center of the support structure or in the corner of the leader board. When two permanent pallet identification transponders are used, mounted at opposite corner of the leader boards, both transponders shall carry identical GRAI-96 data. Extreme care must be used in programming and installing identical RFID transponders as errors which result in having two differently programmed transponders on the same pallet can have serious consequences of misidentification. When multiple GRAI-96 RFID-enabled labels are used on a returnable container to identify that specific container, each GRAI-96 RFID-enabled label will have identical GRAI-96 data structure. Placement shall conform to the requirements of Section [7.4](#).

9 Non-conveyable and non-palletized materiel

Non-conveyable materiel is typically items that are too large, too heavy, and/or too irregularly shaped to be carried on a conveyor. The biggest difference between conveyable and non-conveyable materials lies in how the RFID enabled label or tie-on tag is read.

9.1 RFID reader assumptions

Non-conveyable materials are typically read with handheld readers, carried to the RFID-enabled label or tag. These readers may incorporate bar code as well as RFID readers. This is typically a short range reading application. To improve reading performance, the user may lift tie-on tags away from the material and/or move or reorient the reader for reliable reading.

9.2 Guidelines for some common types of objects and packages

MIL-STD-129 contains some guidelines for and examples of the Military Shipping Label placement on non-conveyable material (see Section [2.1.1](#)). These should be utilized for placement of RFID enabled labels and tie-on tags (see Section [4.1.4](#)).

9.3 Label printed format and transponder data structure

The printed label format and transponder data structure selection should correspond to Section [7.3](#).

9.4 Use of multiple RFID-enabled labels

Use of multiple RFID enabled labels on the container or unit load should conform to Section [7.4](#).

Annex A Design terms for RFID-enabled Labels

Figures A-1 and A-2 show commonly used configurations of 1-up die cut pressure-sensitive roll and fanfold RFID-enabled labels. In both figures, the finished dimensions of the die cut label is W in width and L in length. The backing, or release liner is assumed to be S in width, with equal edge margin on each side. The inter-label gap, G , together with the label length, L form a label repeat distance $R = L + G$.

Figure A-1. Label roll dimensions

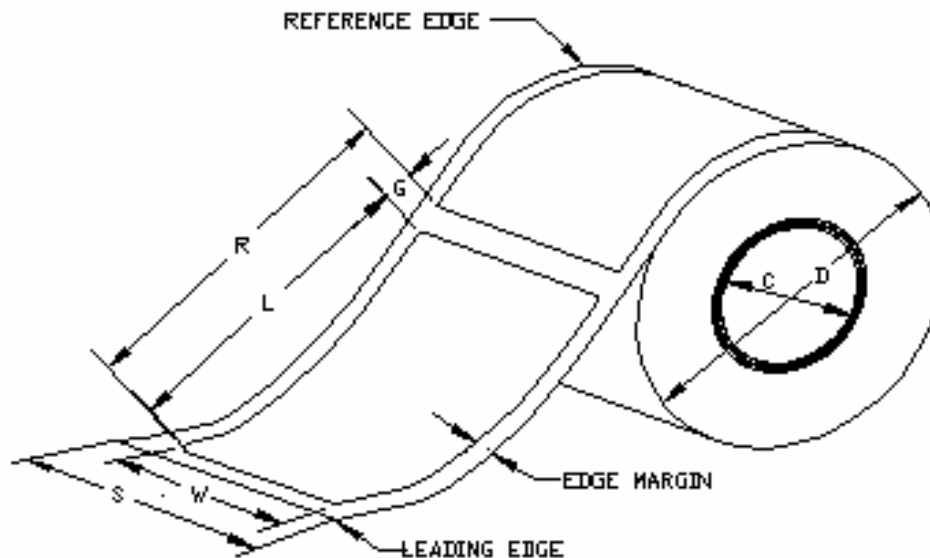

Roll labels are assumed to be wound on a core of inner diameter C and the finished outer roll diameter is assumed to be D .

Fanfold (or Z-fold) labels are shown in Figure 2. The dimensions W , L , S , G and R have the same meaning as in the roll configuration in Figure A-1. Note that a perforation is assumed in the center of the inter-label gap, to enable folding. Fanfold labels are finished into packs of dimension S wide by E long by F high. Note that the pack length E must be an exact multiple of the repeat distance, R .

In both Figures A-1 and A-2, the Leading Edge of the roll or pack is identified. It is assumed to be the release liner edge approximately $G/2$ long preceding the first label edge. This is because the tear-off bar (see Figure A-3) normally forms the reference line of position in the printer-encoder.

In Figure A-3, the label detail is shown with the die-cut label positioned at rest in a typical printer-encoder. The important consideration here is that the transponder location be correctly matched to the encoding antenna position in the intended printer-encoder.

The transponder's transverse dimension is defined as "A" and its longitudinal dimension is "B". The internal placement of the transponder inlay or antenna edge is measured as distance "X" from the

Reference Edge, and “Y” from the Leading Edge, which is assumed to be coincident with the printer-encoder’s tear-off bar, when the label is at the rest position prior to encoding and printing.

Figure A-2. Label fanfold pack roll dimensions

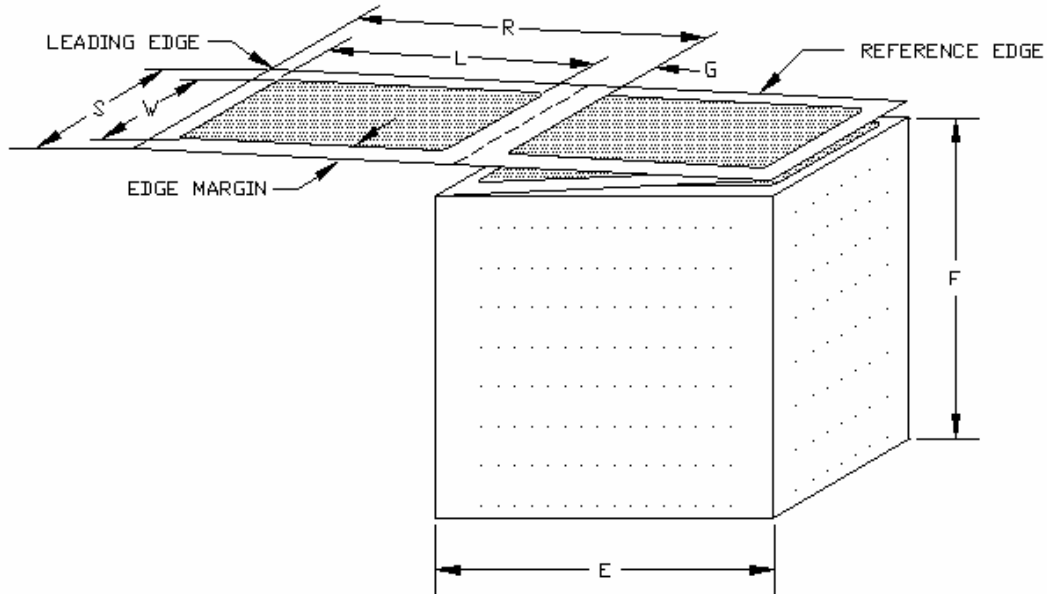
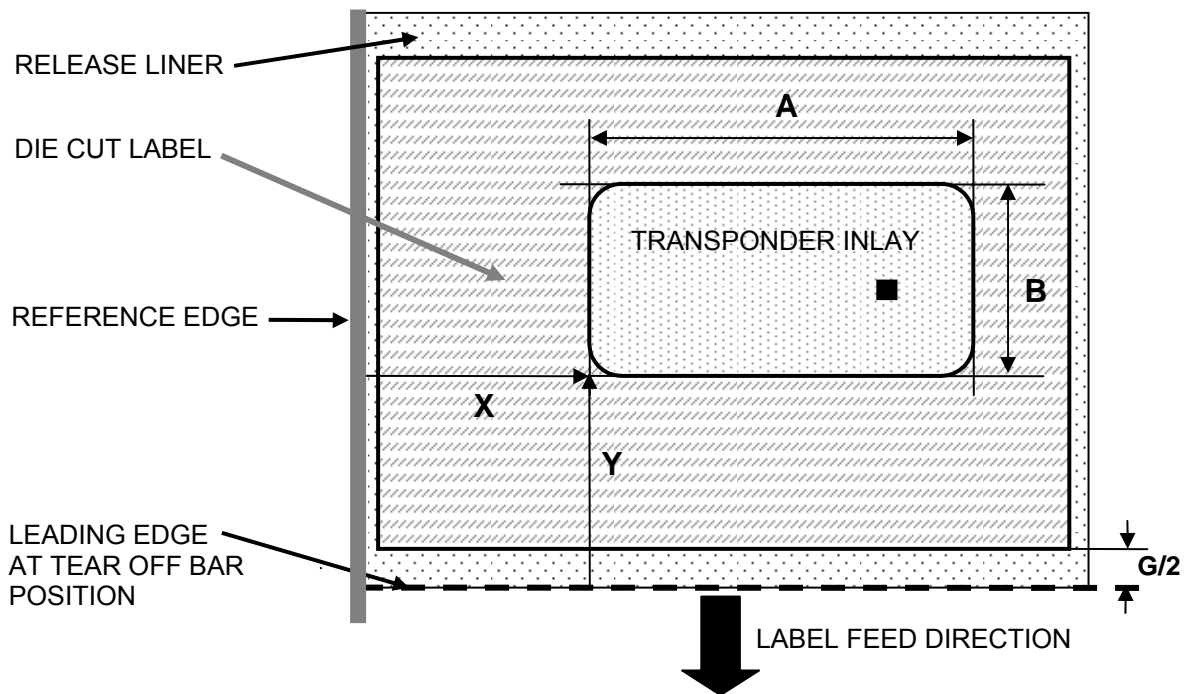

Figure A-3. RFID-enabled label internal layout as shown in a typical printer-encoder



Annex B AIM RFID Mark for RFID-enabled labels

The Association for Automatic Identification and Mobility (AIM Global) has developed a public-domain system of printed visual identification for RFID-enabled labels to indicate the presence of an embedded RFID transponder. This AIM RFID Mark consists of a unique, public domain logo with a two-character code (shown as “B8” in the illustrations below) to indicate the frequency range and data structure conformance standard and in certain cases, the data structure type contained within the encoded RFID transponder.

The two forms of the AIM RFID Mark are:



Either form may be used; it is recommended to use the form which most visually striking on the printed RFID-enabled label material. The logo should be printed no smaller than 13 mm (1/2 in) square, in any color. There shall be a minimum 3 mm (1/8 in) clear, unprinted area around the mark.

The two-character codes to be used with the approved data structures for Department of Defense applications in the AIM RFID Mark on with UHF RFID-enabled labels are shown in Table B-1.

Please refer to the AIM Global website (<http://www.aimglobal.org/rfidmark.asp>) for the complete list of current assignments and downloadable graphics files of the AIM RFID Marks defined in Table B-1. The actual graphics are shown in Figure B-1. Codes not currently assigned are reserved for future use.

Table B-1. Coding of the AIM RFID Mark when used on RFID-enabled labels

2-Character Printed Code	Transponder Frequency †	Data Structure Defining Agency	Bit Length	Data Structure Type
E*	860-960 MHz	EPCglobal ††	N/A	EPCglobal-compatible readers/encoders
E0	860-960 MHz	EPCglobal ††	96	GID-96 General Identifier
E1	860-960 MHz	EPCglobal ††	96	SGTIN-96 Serialized GTIN
E2	860-960 MHz	EPCglobal ††	96	SSCC-96 Serial Shipping Container Code
E3	860-960 MHz	EPCglobal ††	96	SGLN-96 Serialized Global Location Number
E4	860-960 MHz	EPCglobal ††	96	GRAI-96 Global Returnable Asset Identifier
E5	860-960 MHz	EPCglobal ††	96	GIAI-96 Global Individual Asset Identifier
M*	860-960 MHz	US DoD	N/A	Indicates DoD compatible readers/encoders
M0	860-960 MHz	US DoD	64	UID-64 64-bit form of Unit Identification
M1	860-960 MHz	US DoD	96	UID-96 96-bit form of Unit Identification
M2	860-960 MHz	US DoD	256	UID-256 256-bit form of Unit Identification

† Meeting local UHF regulatory regulations; see Section 3.2 for further information

†† See EPC™ Tag Data Standards Version 1.1 Rev 1.2, Annex D, Section D.4.4

As an additional visual aid for workers, two character codes with an asterisk are intended to identify RFID hardware (readers and printer/encoders) compatible with the relevant standard (e.g., E* identifies equipment compatible with EPCglobal standards; M* with these MSL labeling guidelines).

Figure B-1. AIM RFID Mark graphics

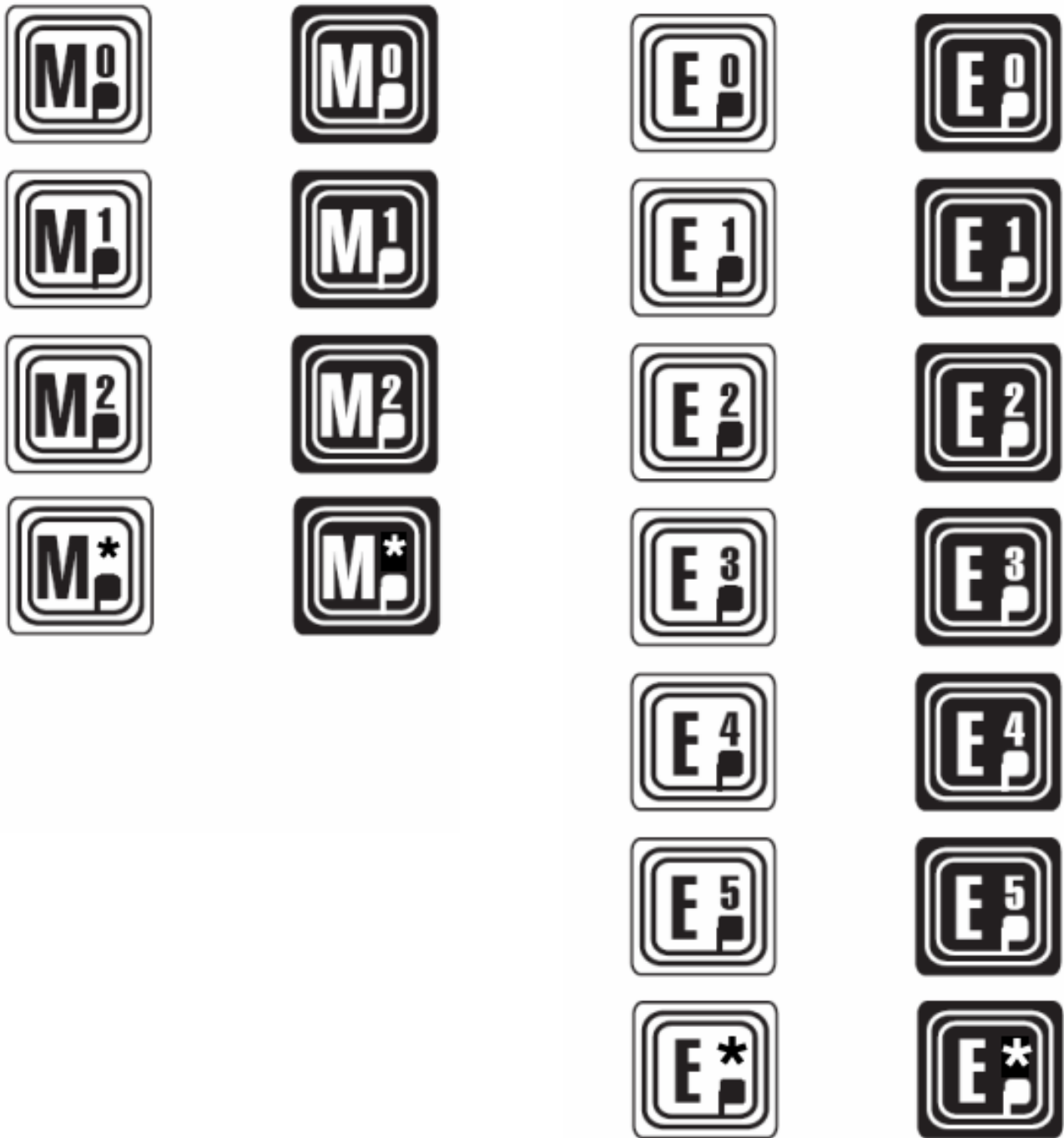

Annex C Optimizing RFID-enabled label placement

While the visual inspection methods described in Section [6.2](#) may be used to guide RFID-enabled label placement, a more quantitative method is useful in both confirming results and in determining the best transponder selection, polarization and placement on the transport package in terms of reader performance. Use of this method will help ensure that the labeled transport package or unit load will meet the minimum read range requirements.

It should be noted that several commercial vendors produce testing software specifically designed to optimize tag type and location selection. These programs employ a scientific methodology that can report in a statistically significant manner the expected performance of various transponders at various locations on an object. It is also important to understand performance at the various frequencies and power levels utilized in international commerce.

The laboratory method described here requires a minimum of equipment and gives *relative (not absolute)* measurements of read range performance (*not conformance*) that may be easily compared between transponders and labeled packages made in the same test lab. By testing the same transponders and packages in multiple laboratories, meaningful correlations of test results between labs may be made.

For standardized performance measurement, the methods of ISO 18046 should be followed. Conformance measurement should be performed utilizing the methods of ISO 18047 (see Sections [2.5.3](#) and [2.5.4](#) respectively).

C.1 Equipment

- C.1.1 An indoor or outdoor facility of sufficient size that there are no large metal objects or vehicles within 10 m (33 ft) of the front or side of the test antenna
- An outdoor parking lot works well as a temporary facility
 - If indoor, the ceilings should be as high as possible, and the floor should be non-metallic. (Ideally, use an anechoic chamber)
- C.1.2 A UHF RFID reader of the appropriate frequency designed for fixed-mount applications, together with a fixed-mount UHF RFID antenna having circular or crossed polarization
- Both the reader and antenna should be types approved for use on conveyors in Defense Logistics Agency depots, and compliant with the appropriate radio regulations
 - The reader must have either programmable or manually step-adjustable output power
 - Both the reader and antenna should have a single antenna connector
 - Readers having integral antennas may be used
- C.1.3 A computer with appropriate reader driver software is connected to the reader. If the computer has an internal wireless LAN link, it should be disabled
- C.1.4 A movable antenna mounting stand (preferably non metallic) having the ability to adjust antenna height over the range 0.6 to 2 m (2 to 7 ft), as well as its pointing direction
- C.1.5 A plastic or wooden table on which to set the transport package under test. Nominal top surface height 75 to 90 cm (29-36 in). It must be strong enough to support the heaviest transport package (24.6 kg or 55 lbs). A molded plastic or structural foam patio table is a good choice. Preferably, replace any metal fasteners with Nylon® fasteners
- C.1.6 Computer and RF coaxial cabling as required. See notes in Section D.3.1.

C.2 Facilities Set up

Ideal test environments are specified in Annex A of ISO 18046 (see Section [2.5.4](#)). While such facilities are necessary for accurate absolute measurements, the simplified method described is much less costly and adequate for the purpose of guiding transponder selection and placement.

The antenna stand should first be set up in a location at least 10 m (33 ft) from any wall or metal object as in Figure C1. This is not always possible; as an alternative just try to place the antenna so that it is as far as possible from metal objects in front of it.

Note: Mounting anechoic foam tiles or cones on plywood panels and setting them on three sides surrounding the test table can obtain additional RF isolation. Conductive black carbon-loaded foam may also help, especially when used in one or more layers with a total thickness ≥ 10 mm ($\geq 3/8$ in).

The antenna (shown as a black box in Figure C1) should be mounted on the stand to permit height adjustment over the full range. If cross-polarized rather than circularly polarized, set the two polarizations along the vertical and horizontal axes. Ensure that the antenna and stand are well grounded.

The transport package as set on testing table (see C.1.6) is shown as cross-hatched in Figure C1. It should be set up approximately 3 m (11 ft) directly in front of the antenna. All other equipment should be located on a standard table or bench set at least 2 m (7 ft) behind the antenna. Avoid running any cables into the area between the antenna and transport package-testing table.

Figure C1 – Nominal package test facilities layout

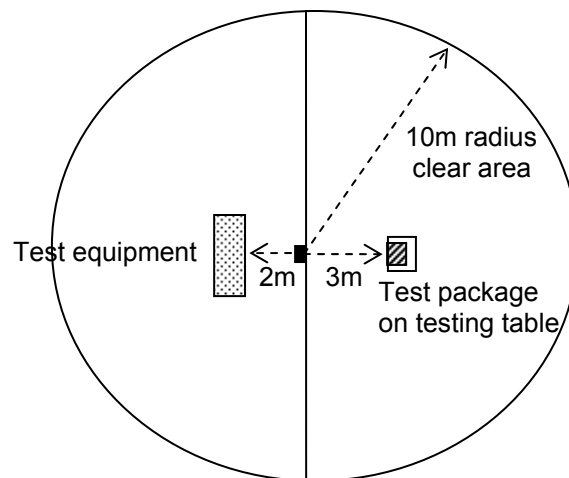

Ensure that there are no active RFID readers within 30 m (100 ft) of the test package *in any direction* even if there are intervening walls, ceilings or floors. As a general practice, cellular telephones, cordless telephones, cordless earphones or speakers, Blue Tooth-connected devices and 802.11 wireless LANs should not be used within that same 30 m (100 ft) radius. This is because certain transponder antennas are resonant at multiple frequencies, causing the chip to be activated by an external RF source rather than the test reader and antenna, therefore resulting in false readings of activation power threshold for the transponder under test.

C.3 Equipment setup

C.3.1 RF cabling considerations

The coaxial cable connecting to the antenna should be long enough to allow the antenna stand to be moved to within 1 m (40 in) of the package and over the full antenna height range. Connect the single antenna port on the detached antenna to the single antenna port on the reader. The same cable should always be used to eliminate measurement variation due to different cable attenuations.

Poor quality coaxial cables can induce erratic measurement errors that are not separable from poor transponder performance. To protect against these problems:

- Ensure that cable is of the proper impedance (generally 50 ohms) to match the RF devices and connectors used, and select larger-diameter, low attenuation cable
- Readers and antennas normally use 50-ohm type N, BNC or SMA connectors (low-cost 75-ohm type F home CATV wiring connectors should *not* be used). Gold plated connectors are recommended for reliability
- Connectors where the cable shield is attached by crimping rather than held by screw-in ferrules generally have better long-term connection reliability, especially under flexure

C.3.2 Reader setup

This set up requires supporting software to set the reader power level from the computer. This is normally available as support diagnostic software from the reader manufacturer.

If the reader manufacturer has not calibrated the power output against the programmed step values, it is recommended that it be done using an RF power meter of the appropriate frequency range and power handling capability. Calibration should be in decibels (in dBm or dBw) at each power level setting.

If the receiver section of the RFID reader has programmable or adjustable sensitivity, it should be set to the “default” or “normal” sensitivity.

C.4 Test methodology

This setup may be used for evaluating UHF transponder sensitivity in free air, or when mounted in RFID-enabled labels on corrugate, plastics, metal boxes, or other container materials.

What is fundamentally measured is the reader power margin in decibels above the transponder power-up threshold to ensure consistently reliable reading at a fixed distance. The threshold is the reader power level at which the tag can no longer be read reliably, either because there is not enough power output to the antenna to activate the chip or because the backscatter signal is too weak to be detected by the receiver in the RFID reader.

C.4.1 Taking threshold power measurements

There is not always a sharp reading threshold. The best reader software will attempt a certain number of reads, or reads per second, and measure either the % of good reads or the % of failures. Less useful software may only show good reads; but the rate of good reads can be estimated visually by watching the screen. A good threshold to use is the reader power setting (or reader power attenuation value) at the 50% good read rate point. The key to good measurement practice is consistent application of technique.

While it would appear logical to start at the maximum power and monitor the percent good reads as the power is slowly incrementally reduced, this can lead to inaccurate threshold measurements due to hysteresis effects in the chip power circuitry. More accurate measurements are obtained by tuning off the reader power between trial setups. Then starting at the lowest reader power, increase the reader power

until the threshold power value is found for an approximately 50% good read rate. Record that value, in decibels. In a given test, the best comparative result is the lowest reader threshold power level realized.

C.5 Transponder and RFID-enabled label evaluation

Most transponder specifications are quoted in terms of free-air performance. These values are not always useful in practice, as the transponder is nearly always inside a label and/or as mounted on some type of packaging material or object that has RF absorption, reflection or scattering properties. This test setup will enable measurement of the transponder under more realistic circumstances.

C.5.1. Measurement setup

An empty corrugated case makes a good test fixture. Place the case at the edge of the testing table with the side to be labeled facing the antenna.

It is recommended that the transponder or the RFID-enabled label samples be adhered to very thin Mylar® or polyester, or PET sheets with a clear size border of at least 50 mm (2 in) for ease in taping to transport packaging during placement tests.

Using one or more 50 mm (2 in) pieces of vinyl electrical tape (for ease of clean removal from the package), lightly tape the test sample by its border to the center of the case face. Adjust the height and orientation of the antenna to point at the center of the test sample at the center of the target area.

If the transponder cannot be initially activated at the highest programmed reader power setting, then move the antenna closer to the transponder, initially to 2 m (80 in) then 1 m (40 in) if necessary.

To ensure adequate dynamic range for practical measurements, ideally find a distance at which the transponder activates at no more than 25% of maximum reader power (i.e., at least –6 dB below maximum power).

Record the exact distance between the antenna face and the transponder center. Set this power level as the 0 dB reference power level for subsequent measurements.

C.5.2 Evaluating transponder lot quality

When possible, obtain transponders with performance data specified the manufacturer based on tests conducted according to the methods of ISO 18046 (see Section [2.5.3](#)) for reference purposes.

Test a representative group in an identical manner, recording the “free air” threshold power value taken as described in Section [C.4.1](#) above. For reference purposes, it is suggested that three types of representative samples be marked and kept: Least sensitive, average sensitivity, and most sensitive.

The least sensitive transponder samples are especially useful for use in transport package evaluation (see Section [C.6](#)), as they represent the “worst case” of transponder performance on the package.

C.5.3 Evaluation effects of transponder orientation

Some transponder antenna designs are much more orientation sensitive than others. Rotating the transponder through one or more axes and measuring the threshold power values at known angles can evaluate this property.

C.5.4 Influence of packaging materials

Transponder samples can be taped to or permanently mounted on different packaging materials to determine their detuning effects on transponder read distance by measuring changes in the threshold power value. Always use the same size material sample and center the transponder on it.

Note that some transponder designs actually may perform better when mounted on certain packaging materials than in free air, as they were designed to use the packaging material as part of the antenna's tuning (see Section [6.3](#)).

C.5.5 Frequency influence

RFID enabled labels on packages shipped between continents may need to operate at multiple reader frequencies and differing power levels. By using readers and antennas compliant with differing local radio regulations to evaluate the same transponders, the acceptability of various transponders at different reading frequencies can be determined.

C.5.6 Combination testing

Any of the above tests can be combined in a logical matter to reduce the total number of tests performed.

C.6 Testing transport packages

This setup may be used for quantitative best transponder selection, polarization and placement on the transport package in terms of reader performance

C.6.1. Measurement setup

Place the test package at the edge of the testing table with the side to be labeled facing the antenna. Adjust the height and orientation of the antenna to point at the center of the target area (see Figure 5 in Section [7.1.1](#)).

The test transponder should be selected from a known tested group of transponders (see Section [C.5.2](#) above), preferably the low-sensitivity group to ensure “worst-case” performance. It is recommended that the transponder or the RFID-enabled label samples be adhered to very thin Mylar® or polyester, or PET sheets with a clear size border of at least 50 mm (2 in) for ease in taping to transport packaging during placement tests. Using one or more pieces about 50 mm (2 in) of vinyl electrical tape for ease of removal, lightly tape the transponder sample by its border at the center of the target area.

If the transponder cannot be initially read at the highest programmable reader power setting, then move the antenna closer to the transponder, initially to 2 m (80 in) then 1 m (40 in) if necessary. Note that if the transponder, when mounted on the transport package, cannot be read at full power when the antenna is placed less than 1.5 meter (60 in) from the transport package in this test, then it is unlikely to meet the requirements of Section [7.1.1](#) in practice.

To ensure adequate dynamic range for practical measurements, ideally find a distance at which the transponder activates at no more than 25% of maximum reader power (i.e., at least –6 dB below maximum power).

Record the exact distance between the antenna face and the transponder center. Set this power level as the 0 dB reference power level for subsequent measurements.

C.6.2 Taking measurements

Follow the threshold power measurement technique described in Section [C.4.1](#) above.

C.6.3 Constructing a transponder placement map

An RFID-enabled label can be taped to at different positions in the target area (see Figure C2) to determine the effects of RF absorption, scattering, reflection or other detuning effects of the transport package contents on transponder read distance.

Step the position of the RFID-enabled label across the target area, and measure and record the threshold power value in decibels above or below the 0dB reference power level at each position, constructing a

“placement map” of threshold power values. The label position with the minimum threshold power will give best reading performance.

Figure C2. An example of a measured transponder placement map

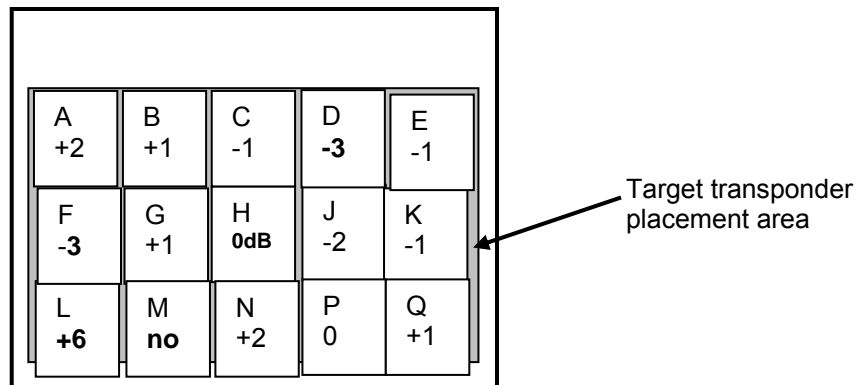

Figure C2 shows an example of a placement map for an arbitrary filled transport case. The 0 dB reference power level is set at point H in the approximate center of the target placement area (see Section [7.1.1](#) for target area definition).

Threshold power levels relative to the 0dB reference power are then measured with the RFID-enabled label taped at all other points A through Q. These show a range from -3dB at points D and F to $+6\text{dB}$ at point L. Point M was a “no read”, the maximum reader power was not sufficient to read the transponder.

The best placement would be at point D, because it not only has the lowest threshold power level, but also because the points around it are also favorable, giving a better tolerance for actual label placement than point F, which is surrounded by unfavorable values. Note that the threshold power value at point D would probably also be less affected by a shift in position of the contents within the case than at point F.

Multiple transponder or RFID-enabled label types can be compared in this manner. Note that some transponder designs actually perform better when mounted on certain packages as they were designed to use the packaging material and/or contents as part of the transponders antenna’s resonant tuning. This often occurs with transponders designed for use on reflective materials or with placed on transport cases containing metal objects.

C.6.4 Evaluation effects of transponder polarization

Some transponder antenna designs are much more orientation sensitive than others. Many RFID-enabled labels utilizing dipole antennas have the transponder placed with horizontal polarization. Rotating the RFID-enabled label and measuring the threshold power values at known angles evaluates this property.

RFID labels with vertically polarized dipole antennas may be useful when the package contains cans, bottles, or other vertically oriented cylindrical objects. Experiment with placement of the RFID-enabled label over the cylinder tangent and over the gap between cylinders and measure threshold power level.

C.6.5 Frequency influence

RFID enabled labels on transport packages shipped between continents may need to operate at multiple reader frequencies and differing power levels. By using readers compliant with differing local radio regulations to evaluate the different types of transponders in RFID labeling transport packages, the acceptability of various transponders at multiple reading frequencies can be determined.

Note that the optimum position of a single type of RFID-enabled label on the transport package may vary with frequency. A compromise location can be determined from comparison of the placement maps.

C.6.6 Combination testing

Any of the above tests can be combined in a logical matter to reduce the total number of tests performed.

C.7 Three-dimensional transport package testing

An obvious variation of this test is to evaluate the RFID-enabled labeled transport package in three dimensions, by moving the reader around the package while keeping it a constant distance from the center of the transponder once placed using the methods in Sections [C.6.3](#). The reader position vector is recorded, and the threshold reader power is then measured using the methods of [C.4.1](#). In this manner, a 3-D map of transponder sensitivity can be plotted, where the transponder sensitivity vector length is defined as:

$$\text{Transponder sensitivity (dB)} = \text{Maximum Power (dB)} - \text{Threshold power (dB)}$$

Note that the transponder sensitivity is a relative value, always positive, *that effectively measures the reader power margin over transponder activation threshold* in each vector direction for a reader that is operating at maximum power and a constant distance from the transponder.

Figure C3 shows two cases, SKU A and SKU B, containing the different types of objects but using the same type of transponder. As evaluated in three dimensions, the transponder sensitivity range pattern around each object is shown. Its shape is determined by the make up of the objects in the case and the RF-enabled label type and placement.

The case on the left, SKU A, has a complicated, non-uniform pattern of threshold read range, with strong sensitivity lobes in certain directions, and sensitivity nulls in other directions. While on conveyor, it would require precise reader orientation of the reader and case for the highest probability of a good read. The fact that the threshold distance has nulls on the side of the case reduces its probability of a good read as the case is moved at high speed (in the direction of the arrow) along a conveyor.

The object on the right, SKU B, has a highly predictable and uniform read range around the top and sides of the case. It would be easy to read from almost any position above or from the side of the case. Since the threshold sensitivity changes slowly as the case is moved along the conveyor, a reader will have the longest continuous time to read the transponder, and thus the best probability of a good read as the case is moved at high speed along the conveyor.

Figure C3. Three-dimensional transponder sensitivity for two different objects

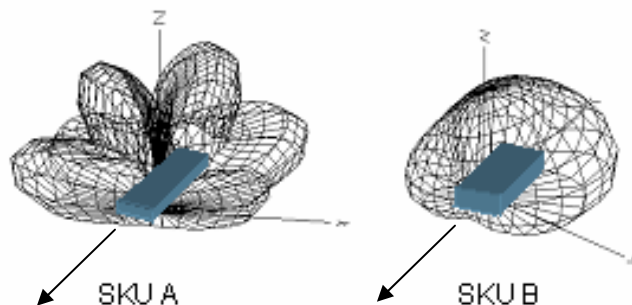

Different transponder antenna designs will show widely varying sensitivity patterns on the same object. Figure C3 could also represent two cases containing the same object, where a high-Q or highly directional transponder antenna on SKU A is highly influenced by the case contents, but a more omnidirectional and content-insensitive transponder on SKU B is less affected by the case contents. Here again, SKU B has the preferable transponder sensitivity map.